

# **IDK-LOK**

Fittings & Valves

## *Block & Bleed Valves Monoflange*



VALVE AND FLOW CONTROL SPECIALISTS  
SERVICE AND RELIABILITY

No. DBB/MONO-1  
July 2015



Valve and Flow Control Specialists - AUSTRALIA - Email: [sales@valveandflowcontrolspecialists.com](mailto:sales@valveandflowcontrolspecialists.com)



**VALVE AND FLOW CONTROL SPECIALISTS**  
*SERVICE AND RELIABILITY*

Contact: VALVE AND FLOW CONTROL SPECIALISTS

Brisbane - Darwin - Sydney - Melbourne AUSTRALIA

Email: [sales@valveandflowcontrolspecialists.com](mailto:sales@valveandflowcontrolspecialists.com)

**Primary Isolation Valve Applications**

<b>Market</b>	<b>02</b>
<b>Application</b>	<b>02</b>
<b>Installation Advantages</b>	<b>02</b>

**Technical Specification**

<b>Ball Valve Specifications</b>	<b>03</b>
<b>Outside Screw and Yoke(OS&amp;Y) Needle Valve Specifications</b>	<b>04</b>
<b>Globe Type Needle Valve</b>	<b>05</b>

**Integral Block & Bleed Valve**

<b>Ordering Information</b>	<b>07</b>
<b>Product Range / Weights and Dimensions</b>	<b>10</b>

**Monoflange**

<b>Ordering Information</b>	<b>14</b>
<b>Product Range / Weights and Dimensions</b>	<b>15</b>

## Primary Isolation Valve Application

### Market

- Offshore oil and gas production
- Offshore terminals
- Chemical, petro-chemical, refining
- Control panel manufactures
- Process/power industry contractors
- Compressor manufactures
- LNG carrier

### Application

- Double block and bleed instrument isolation
- Gauge isolation
- Instrument drain
- Chemical injection connection
- Sample connection
- Chemical instrument isolation
- Piping/instrument interface
- Direct mounting of instruments
- Remote mounting of instruments

### Installation Advantages

- More compact design
- Reduced weight
- Reduced height
- Reduced leakage point
- Reduced effect of system vibration
- Supporting bracket are not required
- Reduced bending moment acting on the vessel branch fitting weld
- Reduced installation cost
- Reduced gasket and bolting

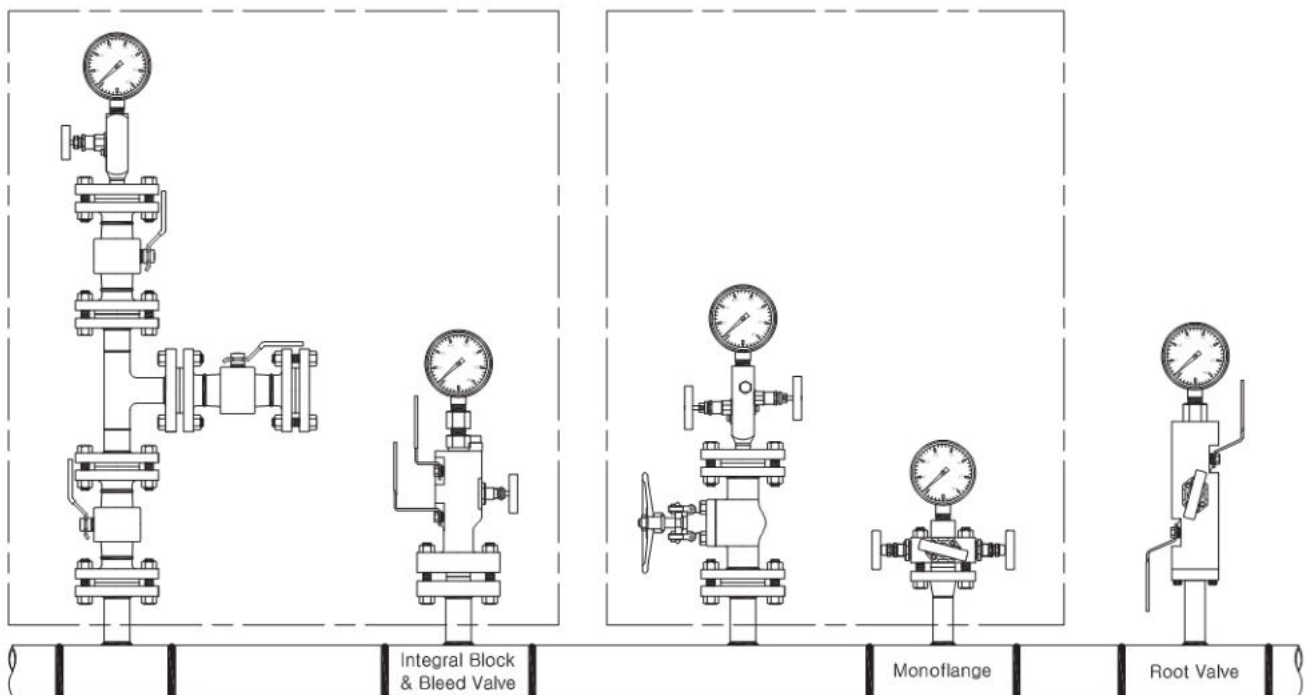

### Integral Block & Bleed Valve

- Ball and Globe Type Needle Valves
- Flanged and Threaded Connections
- Integrally Forged Body

### Monoflange

- Globe Type Needle Valves
- Flanged and Threaded Connections
- Slimline Integrally Forged Body

### Root Valve

- Ball and Globe Type Needle Valves
- Weld or Threaded Connections
- Direct Connection to the Vessel

## Technical Specification

### Ball Valve

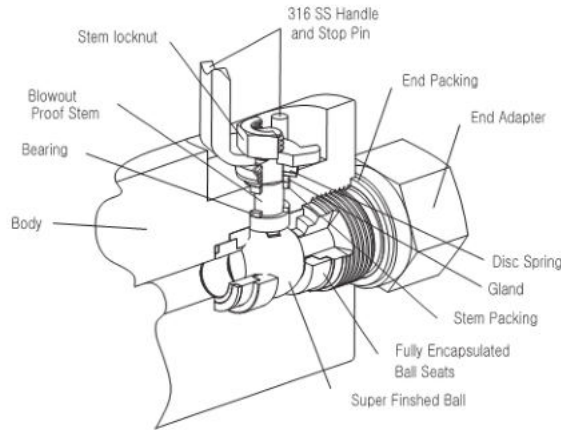

### Features

- Quarter turn actuation.
- Blowout proof stem design.
- Micro-finished ball for long service life.
- Anti static design as standard.
- Live-loaded stem packing ensures positive sealing across the pressure and temperature range.
- Live-loaded seats maintain system seal through changes in pressure and temperature.
- Bore size available : 3/8" (9.5mm), 1/2" (14mm), 3/4" (19mm), 1" (25mm), 1 1/2" (38mm), 2" (50mm).
- Lockable with nylon sleeve lever handle is standard.
- Pressure rating up to 10000 psig (690 barg).
- Temperature rating - 71 to 482 °F (-57 to 250 °C).

### Pressure - Temperature Ratings

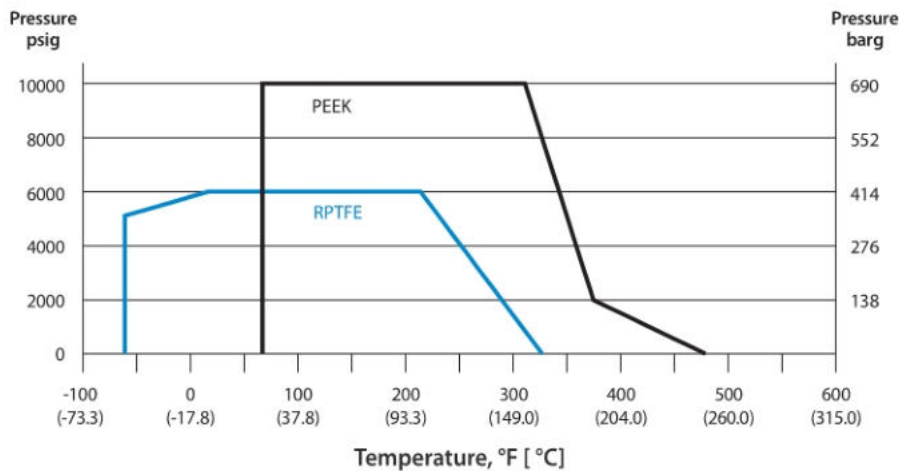

### Material of Construction

Ball Valve Components				
No	Description	Material Grade / ASTM Specification		
1	Body	A182 F316	A105	A182 F51 Inconel 625
2	End Adapter	A479-316	A105	UNS S31803 Inconel 625
3	Stem	A479 TYPE316		UNS S31803 UNS N06625
4	Ball	A479 TYPE316		UNS S31803 UNS N06625
5	Handle & Stop Pin	SS316		
6	Stem Locknut	SS316		
7	Bearing	PEEK		
8	Seat	RPTFE or PEEK		
9	End Packing	GRAPHITE		
10	Gland	SS316		
11	Stem Packing	GRAPHITE		
12	Dis Spring	INCONEL X750		

### Outside Screw and Yoke(OS&Y) Needle Valve

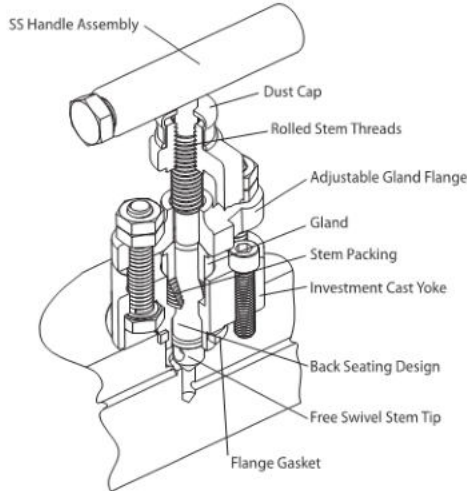

#### Features

- Investment cast yoke is precision cased for perfect stem alignment.
- Standard non-rotating free swivel stem tip.
- Roll threaded and hard chrome plated stem for long valve life.
- Stem packing below thread design prevents media contamination and thread lubricant washout.
- Back seating design provides secondary stem sealing and prevents stem blowout.
- Adjustable gland flange allows packing adjustment.
- 0.2 in. (5mm) bore.
- Pressure rating up to 6000 psig (414 barg).
- Temperature rating - 71 to 1022 °F (-57 to 550 °C).

#### Pressure - Temperature Ratings

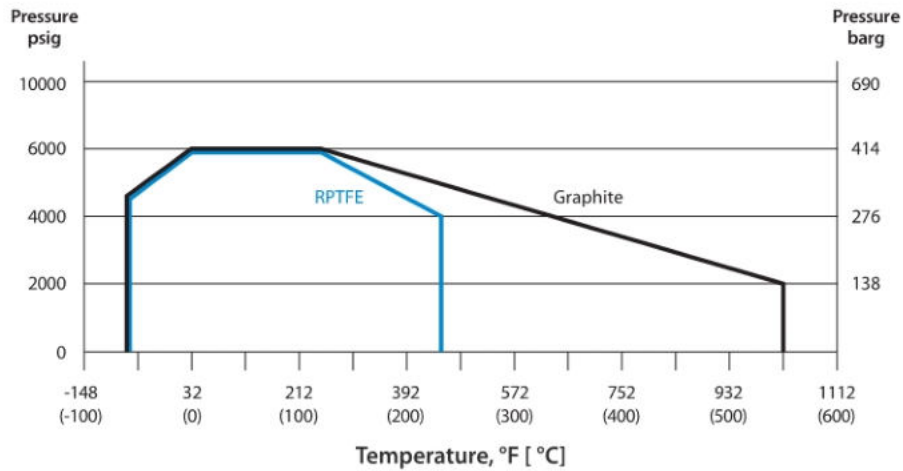

#### Material of Construction

Yoke Needle Valve Component				
No	Description	Material Grade / ASTM Specification		
1	Body	A182 F316	A105	A182 F51 Inconel 625
2	Stem	A479 TYPE316		UNS S31803 UNS N06625
3	Gland Flange	A479 TYPE316		UNS S31803 UNS N06625
4	Yoke	A351 CF8M		UNS S31803 UNS N06625
5	Stem Tip	SS630		UNS S31803 UNS N06625
6	Handle Assembly	SS316		
7	Dust Cap	PLASTIC		
8	Gland	SS316		
9	Stem Packing	GRAPHITE		
10	Flange Gasket	GRAPHITE		

**Globe Type Needle Valve**

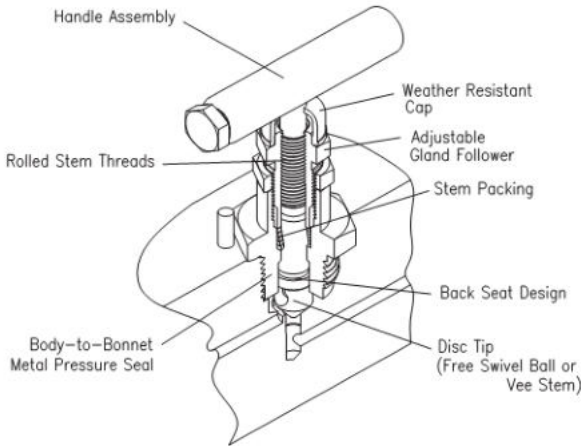

**Features**

- Bar-handled vent is standard.
- External packing adjustment.
- Back seating design provides secondary stem sealing and prevents stem blowout.
- Standard non-rotating free swivel stem tip.
- Roll threaded and hard chrome plated stem for long valve life.
- Stem packing below thread design prevents media contamination and thread lubricant washout.
- Stellite seat is an option for Globe Needle Valve. To order the option, suffix "HS" to the ordering number. i.e., V1F-SNHS, V1F-SCHS, V1F-SDHS, V1FF-DCHS, V1FF-DDHS and V1FF-DEHS.
- Globe needle valve with anti-tamper bonnet (designator - T) is available with a removable T-bar key to prevent unauthorized operation and release of fluid through the vent port to atmosphere. The T-bar key is supplied separately or alternatively the key can be chained (designator - TC) to the valve.
- 0.2 in. (5mm) bore.
- Pressure rating up to 10,000 psig (690 barg).
- Temperature rating -71 to 1,022 °F (57 to 550 °C).

**Pressure - Temperature Ratings**

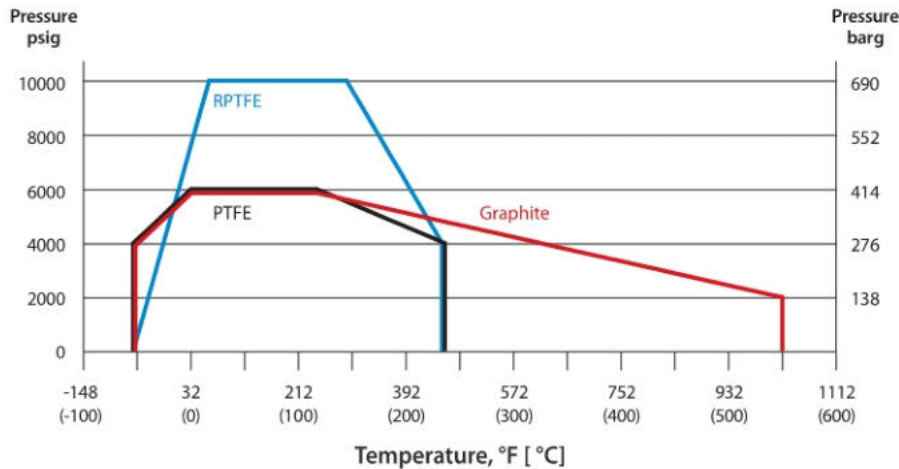

**Material of Construction**

Material of Construction				
No	Description	Material Grade / ASTM Specification		
1	Body	A182 F316	A105	A182 F51 Inconel 625
2	Stem	A479 TYPE316		UNS S31803 UNS N06625
3	Bonnet	A479 TYPE316		UNS S31803 UNS N06625
4	Handle Assembly	A479 TYPE316		
5	Dust Cap	PLASTIC		
6	Packing Bolt	A479-316		
7	Stem Packing	GRAPHITE		
8	O-ring	NBR or FKM		
9	Stem Tip	GRAPHITE		

## Integral Block & Bleed Valve



### Integral Block & Bleed Valve

Are integrally one-piece double block and bleed assemblies, for primary isolation of pressure take-offs, where the valve is directly mounted to the vessel or process pipe. Instruments may be directly mounted to the valve outlet or alternatively remotely with gauge lines/impulse pipe work.

### Features

- Reduced potential leak paths with primary & secondary isolation in one valve.
- Compact ball/OS&Y/needle valve assembly in one DBB.
- Flange construction as per the requirements of ASME B16.5.
- NPT threaded connection to ANSI/ASME B1.20.1.
- Pressure ratings as per ASME B16.34 Class 150 thru 2500.
- Wetted components of Sour gas service valve are selected as per the requirements of NACE MR0175 /ISO 15156.
- Fire tested as per BS 6755 part 2/API 607.
- Anti-Static Device is set between the stem and ball.
- All DK-Lok Double Block & Bleed valves are equipped with two body gasket. The first body gasket is in soft material and second in graphite(if not otherwise required), this combination assures the best seal characteristic in whatever corrosive service as well as giving a fire safe design.
- The Solid ball used by DK-Lok provides straight through flow and real full-port performance characteristics. Hollow ball or cored cavity ball are not used for DK-Lok products.
- Locking device is supplied as standard in order to prevent unauthorized opening & closing. Locking device can lock the valve in either the open or closed position and cannot be breached by removing the lever.
- Every valve is subject to a pressure test in accordance with the standard API 598 or BS 6755 part1. The rated pressure for the applicable pressure class is in accordance with ASME B 16.34 & EN 12516-1/2.
- Each valve is identified on proper name plate and on valve body as required by MSS SP 25, ASME B16.34. Name plate carries all information on rating, size, valve body and trim material. On body, marking includes material designations and heat code and of course the trade mark.



## Ordering Information

### 1. Body Construction

#### One Piece Forged Design

Designator : V1

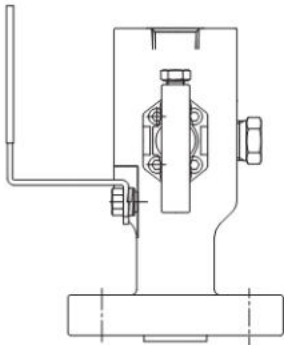

#### Two Piece Bolted Design

Designator : V2

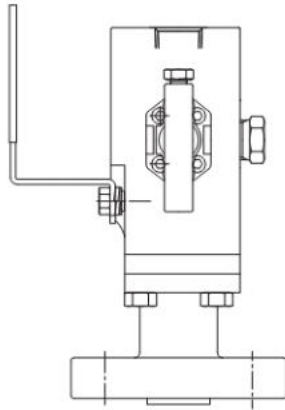

#### Three Piece Bolted Design

Designator : V3

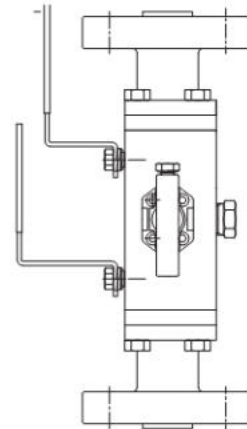

### 2. Process and Outlet Connection

#### Flange to 1/2" NPTF

Designator - F

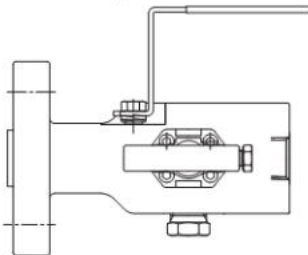

#### Flange to Flange

Designator - FF

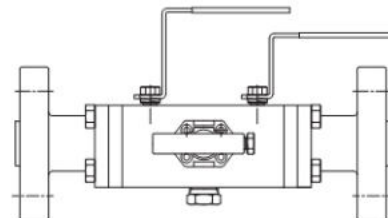

### 3. Single and Double Block and Bleed Valve

#### Single Block and Bleed

Designator - S

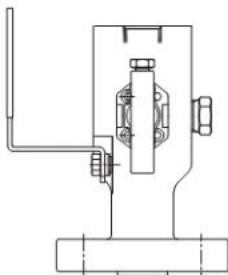

#### Double Block and Bleed

Designator - D

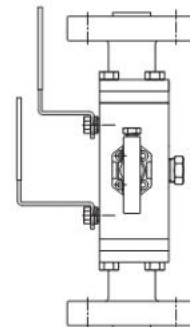

**4. Configuration**

**Single Block and Bleed Valve**

Designator	Block	Vent
B	Ball	Ball
Y	OS&Y	OS&Y
N	Globe Needle	Globe Needle
A	Ball	OS&Y
C	Ball	Globe Needle
D	OS&Y	Globe Needle

**Double Block and Bleed Valve**

Designator	Block	Block	Vent
B	Ball	Ball	Ball
Y	OS&Y	OS&Y	OS&Y
A	Ball	Ball	OS&Y
C	Ball	Ball	Globe Needle
D	OS&Y	Globe Needle	Globe Needle
E	OS&Y	OS&Y	Globe Needle

**5. Process Connections**

Flange Size		Flange Class		Bore Size		Finish Standard	
Designator	Size	Designator	Rating	Designator	Size	Designator	Finish
8	1/2" (DN15)	A	150	Null	Full	1	Raised Faced Smooth
12	3/4" (DN20)	B	300	1	Reduce	2	Raised Faced Serrated
16	1" (DN25)	C	600	2	9.5mm	3	Raised Faced Stock
24	1 1/2" (DN40)	D	900	3	14mm	4	Ring Type Joint
32	2" (DN50)	E	1500	4	19mm		
		F	2500				

**How to order**

Designators	Selected Flange Size	Selected Flange Class	Selected Bore Size	Selected Finish Standard	Intermediate Ordering Number
8A11	1/2" (DN15)	150	9.5mm	Raised Faced Smooth Finish	V1F-SN-8A11
16C31	1" (DN25)	600	14mm	Raised Faced Smooth Finish	V1F-SN-16C31
24D2	1 1/2" (DN40)	900	Full Bore	Raised Faced Serrated	V3F-DC-24D2

## 6. Seat and Packing

Ball Valve Seat Material		OS&Y Packing		Needle Valve Packing	
Designator	Seat	Designator	Packing	Designator	Packing
Nil	Reinforced PTFE	Nil	Graphite	Nil	Graphite
PK	PEEK	PE	PTFE	RP	Reinforced PTFE

### How to order

Designator	Ball Valve Seat Material	OS&Y Packing	Needle Valve Packing	Intermediate Ordering Number
Nil	Reinforced PTFE	Standard Grcking	Standard Graphite	V1F-SNT-84A1-
PKPE	PK : PEEK	PE : PTFE	Standard Graphite	V1F-SCTC-16C1-PKPE
PKPERP	PK : PEEK	PE : PTFE	RP : Reinforced PTFE	V1F-SDT-24D2-PKPERP

## 7. Vent (Bleed) Port

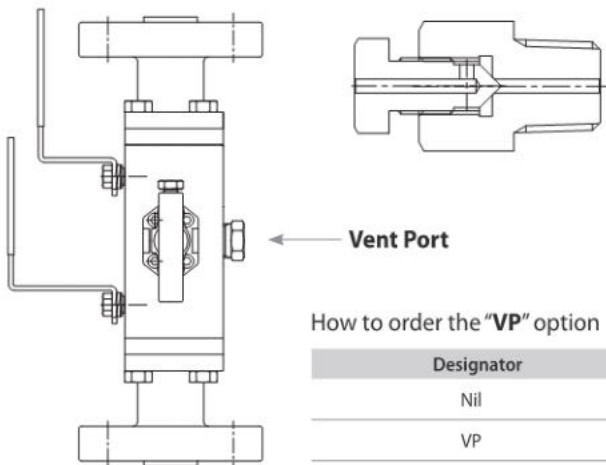

### "VP" option

- Vent port 1/2" NPTF with Hex Plug is standard.
- Vent port with "Vent Plug" is an option with "VP" designator.

### How to order the "VP" option

Designator	On Vent Port	Intermediate Ordering
Nil	Hex Plug	V1F-SC-16C1
VP	Vent Plug	V1F-SC-16C1-VP

## 8. Option, Trim and Body Material

Option	Trim Material	Body Material
SG : NACE MR0175 FS : Fire Tested Design to BS6755 Part 2	Nil : Standard S5316 D : Duplex M : Monel UNS N04400	S : ASTM A182 F316 / F316L C : ASTM A105 D : ASTM A182 F51 M : ASTM B564 UNS N04400 LF : ASTM A350 LF2

**FS :** Optional fire tested design valve is supplied with the following seat & packing materials.

- Ball Seat: Standard Reinforced PTFE
- OS&Y Packing: Standard Graphite Packing
- Needle Valve Packing: Optional Graphite Packing

### Completion of DBB ordering numbers

Complete Ordering Number	Option	Trim Material	Body Material
V1F-SN-8A1-S	No option	No option	S316
V3F-DC-16D4-PKPE-SG-MS	Nace	Monel	S316
V1F-SDT-24DS-FS-S	Fire Safely	No option	S316

Product range / Weights and Dimensions

V1FF Series

9.5mm Bore

One Piece Forged Flange to 1/2" NPTF Single Block Bleed Valve with Ball and OS&Y(or Needle) on Block and Vent.  
 3/8"(9.5mm) and 1/2"(14mm), 3/4"(19mm) Bore Size

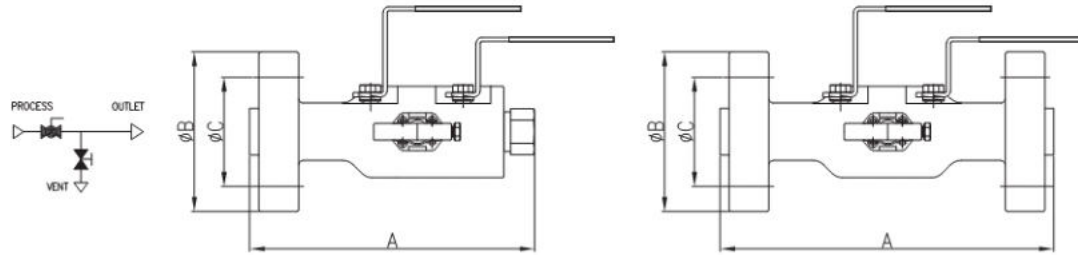

Size(inch)	Class	Dimension(mm)					Weight(kg)	
		A(RF)	A(RTJ)	A(Flange/NPT)	B	C	Flange	Flange/NPT
1/2"	150	188	-	168	88.9	60.5	4.3	3.6
	300	188	193	168	95.2	66.5	5	3.9
	600	188	196	168	95.2	66.5	5.2	4
	900/1500	206	213	176	120.6	82.5	7.9	5
	2500	206	213	176	133.4	88.5	10.8	6
3/4"	150	188	-	168	98.6	69.9	4.9	3.9
	300	188	196	168	117.3	82.5	6.3	4
	600	188	196	168	117.3	82.5	6.5	4.2
	900/1500	206	213	176	130	88.9	9.5	5.6
	2500	206	213	176	139.7	95.3	11	7.1
1"	150	188	193	173	108	79.2	5	3.9
	300	190	195	173	124	88.9	6.3	4.3
	600	190	198	173	124	88.9	6.5	4.5
	900/1500	240	240	195	149.3	101.6	11.5	6.8
	2500	255	255	203	158.8	108	14.3	8.1
1 1/2"	150	198	203	178	127	98.6	7	4.6
	300	218	218	185	155.4	114.3	10.1	6
	600	235	235	204	155.4	114.3	11	6.5
	900/1500	280	280	215	177.8	123.9	16.5	9.4
	2500	316	316	220	203.2	146.1	25.8	14
2"	150	203	213	183	152.4	120.7	9.4	5.5
	300	223	228	190	165.1	127	12.8	6.8
	600	243	253	202	165.1	127	13.4	8.1
	900/1500	288	288	215	215.9	165.1	25.4	14
	2500	313	313	220	235	171.5	36.6	22

V1FF Series

## 14mm Bore

One Piece Forged Flange to 1/2" NPTF Single Block Bleed Valve with Ball and OS&Y(or Needle) on Block and Vent.  
3/8"(9.5mm) and 1/2"(14mm), 3/4"(19mm) Bore Size

Size(inch)	Class	Dimension(mm)					Weight(kg)	
		A(RF)	A(RTJ)	A(Flange/NPT)	B	C	Flange	Flange/NPT
1"	150	231	231	197	108	79.2	7.7	3.9
	300	241	241	197	124	88.9	8.8	4.3
	600	241	241	203	124	88.9	8.8	4.5
	900/1500	261	261	203	149.3	101.6	12.7	6.8
	2500	273	273	203	158.8	108	16.5	8.1
1 1/2"	150	241	241	207	127	98.6	9.1	4.9
	300	251	251	207	155.4	114.3	12.3	6.4
	600	251	251	215	155.4	114.3	12.3	6.9
	900/1500	291	291	215	177.8	123.9	17.7	9.8
	2500	316	316	220	203.2	146.1	27	14
2"	150	241	213	210	152.4	120.7	10.9	5.9
	300	261	241	210	165.1	127	14.1	7.5
	600	261	261	220	165.1	127	14.1	8.4
	900/1500	306	306	220	215.9	165.1	26.6	14
	2500	346	346	230	235	171.5	37.8	22.1

V1FF Series

## 19mm Bore

Size(inch)	Class	Dimension(mm)				Weight(kg)
		A(RF)	A(RTJ)	B	C	
1 1/2"	150	253	253	127	98.6	9.8
	300	263	263	155.4	114.3	13.0
	600	263	263	155.4	114.3	13.0
	900/1500	303	303	177.8	123.9	18.4
	2500	328	328	203.2	146.1	27.7
2"	150	253	253	152.4	127	11.7
	300	273	273	165.1	127	14.9
	600	273	273	165.1	127	14.9
	900/1500	318	318	215.9	165.1	27.4
	2500	358	358	235	171.5	38.6

V3FF Series

## Full Bore

Three Piece Bolted Design Flange to Flange Double Block and Bleed Valve with Ball and OS&Y (or Needle) on Block and Vent.

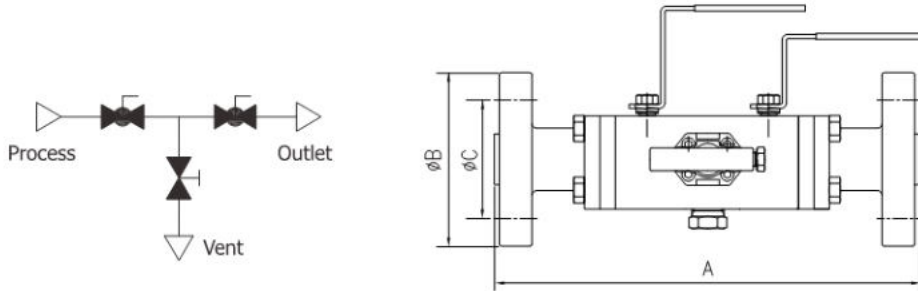

Size(inch)	Bore(mm)	Class	Dimension(mm)				Weight(kg)
			A(RF)	A(RTJ)	B	C	
1/2"	14	150	235	248	88.9	60.5	8.5
		300	241	254	95.2	66.5	9.5
		600	254	254	95.2	66.5	10.0
		900/1500	287	287	120.6	82.5	13.0
		2500	303	303	133.4	88.5	16.0
3/4"	19	150	264	277	98.6	69.9	9.5
		300	277	290	117.3	82.5	10.5
		600	290	290	117.3	82.5	11.0
		900/1500	320	320	130	88.9	16.0
		2500	333	333	139.7	95.3	19.0
1"	25	150	272	285	108	79.2	15.0
		300	279	292	124	88.9	16.7
		600	292	292	124	88.9	17.5
		900/1500	364	364	149.3	101.6	21.2
		2500	377	377	158.8	108	24.2
1 1/2"	38	150	361	374	127	98.6	24.7
		300	367	384	155.4	114.3	27.1
		600	384	384	155.4	114.3	27.9
		900/1500	402	402	177.8	123.9	35.1
		2500	463	466	203.2	146.1	45.5
2"	50	150	390	403	152.4	120.7	48.2
		300	398	411	165.1	127	50.3
		600	416	419	165.1	127	51.1
		900/1500	481	484	215.9	165.1	66.8
		2500	652	655	235	171.5	150.0
	42	2500	652	655	235	171.5	150.0

V3FF Series

## Reduce Bore

Three Piece Bolted Design Flange to Flange Double Block and Bleed Valve with Ball and OS&Y (or Needle) on Block and Vent.

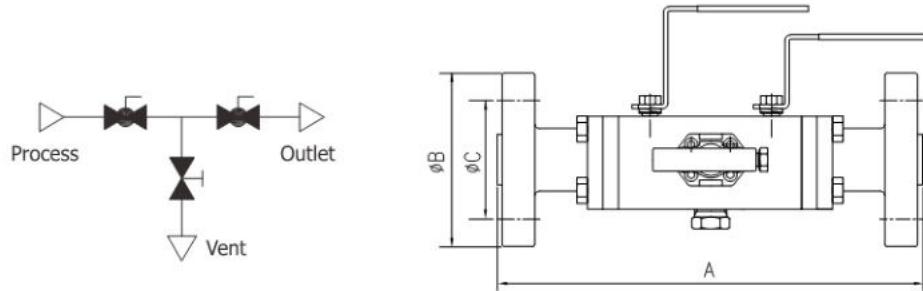

Size(inch)	Bore(mm)	Class	Dimension(mm)				Weight(kg)
			A(RF)	A(RTJ)	B	C	
3/4"	14	150	249	262	98.6	69.9	10.0
		300	262	275	117.3	82.5	11.5
		600	275	275	117.3	82.5	13.0
		900/1500	305	305	130	88.9	16.0
		2500	318	321	139.7	95.3	19.0
1"	19	150	267	280	108	79.2	11.5
		300	281	294	124	88.9	13.0
		600	294	294	124	88.9	14.5
		900/1500	336	336	149.3	101.6	19.0
		2500	350	353	158.8	108	22.0
1 1/2"	25	150	279	292	127	98.6	16.4
		300	285	298	155.4	114.3	20.2
		600	301	301	155.4	114.3	21.0
		900/1500	370	370	177.8	123.9	26.2
		2500	396	399	203.2	146.1	36.6
2"	38	150	364	377	152.4	120.7	25.7
		300	372	383	165.1	127	29.8
		600	390	393	165.1	127	31.2
		900/1500	415	418	215.9	165.1	43.8
		2500	475	478	235	171.5	57.5
3"	50	150	400	413	190.5	152.4	52.7
		300	410	423	209.5	168.1	56.7
		600	428	431	209.5	168.1	58.7
		900	441	444	241.3	190.5	68.9
		1500	500	503	266.7	203.2	84.7
	42	2500	694	700	304.8	228.6	210.0

### Caution

Valves that have not been actuated for a period of time may have a higher initial actuation torque. Packing adjustment may be required during the valve in service.

## Monoflange

- ASME B16.5 flanged inlet connections 1/2" to 3" sizes.
- Standard 1/2" NPT female outlet.
- Bleed port 1/2" NPT female with Hex Plug is standard.
- OS&Y with graphite packing is standard, optional PTFE.
- Needle valve with PTFE packing is standard, optional Graphite.
- Optional fire safe design to BS6755 part 2.
- Optional NACE certification.



### Ordering Information

#### VMS Series (Single Block)

Flange to 1/2" NPTF  
**Isolate** : OS&Y or Needle

Designators	Isolate	Intermediate Ordering #
<b>Y</b>	OS&Y	VMS-Y
<b>N</b>	Globe Needle	VMS-N

#### VMB Series (Single Block & Bleed)

Flange to 1/2" NPTF  
**Isolate** : OS&Y or Needle  
**Bleed** : OS&Y or Needle

Designators	Isolate	Bleed	Intermediate Ordering #
<b>Y</b>	OS&Y	OS&Y	VMB-Y
<b>N</b>	Globe Needle	Globe Needle	VMB-N
<b>D</b>	OS&Y	Globe Needle	VMB-D

#### VMD Series (Double Block & Bleed)

Flange to 1/2" NPTF  
**Primary Isolate** : OS&Y or Needle  
**Secondary Isolate** : OS&Y or Needle  
**Bleed** : OS&Y or Needle

Designators	Primary Isolate	Secondary Isolate	Bleed	Intermediate Ordering #
<b>Y</b>	OS&Y	OS&Y	OS&Y	VMD-Y
<b>N</b>	Globe Needle	Globe Needle	Globe Needle	VMD-N
<b>D</b>	OS&Y	OS&Y	Globe Needle	VMD-D

### Process Connections

Flange Size		Flange Class		Finish Standard	
Designator	Size	Designator	Class Rating	Designator	Finish
8	1/2" (DN15)	A	150	1	Raised Faced Smooth
12	3/4" (DN20)	B	300	2	Raised Faced Serrated
16	1" (DN25)	C	600	3	Raised Faced Stock
24	1 1/2" (DN40)	D	900		
32	2" (DN50)	E	1500		
48	3" (DN80)	F	2500		

### Packing Material

OS&Y Packing	Needle Valve Packing
<b>Nil</b> : Standard Graphite <b>PE</b> : PTFE	<b>Nil</b> : Standard PTFE <b>GF</b> : Graphite <b>RP</b> : Reinforced PTFE

### Option, Trim and Body Material

Option	Trim Material	Body Material
<b>SG</b> : NACE MR0175 <b>FS</b> : Fire tested design	<b>S</b> : SS316 <b>C</b> : Carbon Steel <b>D</b> : Duplex <b>M</b> : Monel	<b>S</b> : SS316 <b>C</b> : Carbon Steel <b>D</b> : Duplex <b>M</b> : Monel



## Product Range / Weights and Dimensions

Single Block

### VMS Series

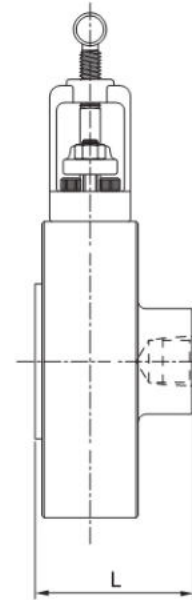
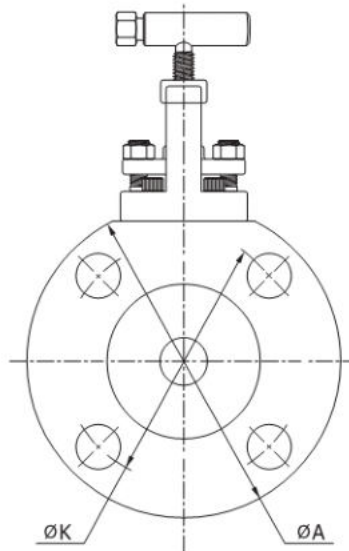
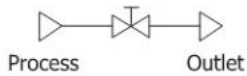

Size (inch)	Class	Dimensions(mm)				Weight (kg)
		L(RF)	L(RTJ)	A	K	
1/2	150	64	-	99	60.3	2.0
	300	64	68	99	66.7	2.0
	600	68	68	99	66.7	2.0
	900/1500	68	68	133	82.5	3.4
	2500	68	68	133	88.9	3.4
3/4	150	64	-	99	69.8	2.0
	300	64	68	133	82.5	3.4
	600	68	68	133	82.5	3.4
	900/1500	68	68	133	88.9	3.4
	2500	73	73	159	95.2	5.5
1	150	64	68	133	79.4	2.4
	300	64	68	133	88.9	3.4
	600	68	68	133	88.9	3.4
	900/1500	73	73	159	101.6	5.5
	2500	73	73	159	108.0	5.5
1 1/2	150	64	68	127	98.4	3.2
	300	69	69	159	114.3	5.5
	600	73	73	159	114.3	5.5
	900/1500	73	73	178	128.8	7.8
	2500	82	84	235	146.1	11.4
2	150	69	73	159	120.6	5.5
	300	69	75	178	127.0	7.8
	600	73	75	178	127.0	7.8
	900/1500	82	84	235	165.1	11.4

Single Block & Bleed

# VMB Series

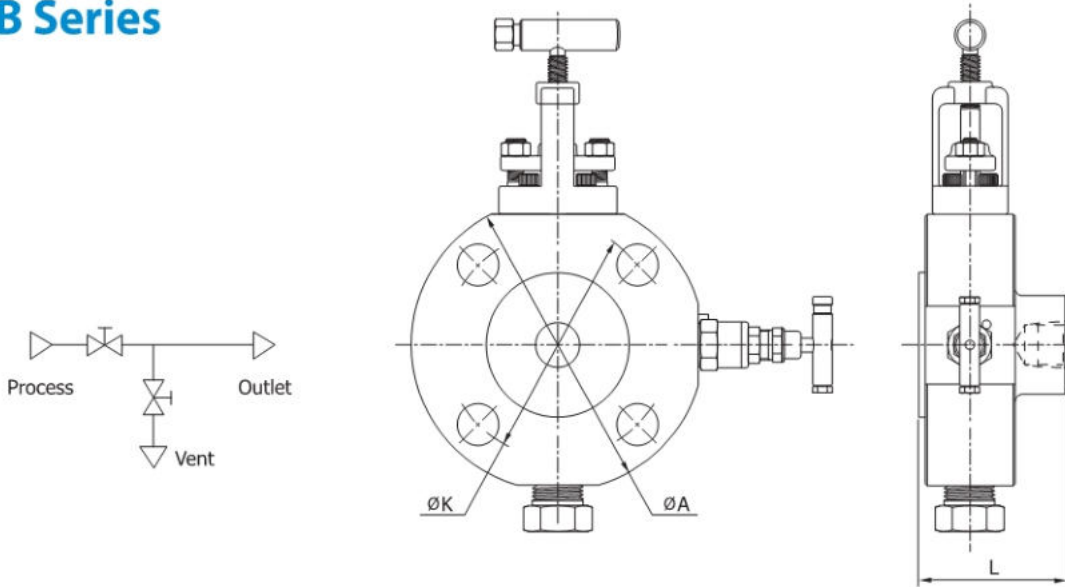

Size (inch)	Class	Dimensions(mm)				Weight (kg)
		L(RF)	L(RTJ)	A	K	
1/2	150	64	-	99	60.3	2.0
	300	64	68	99	66.7	2.0
	600	68	68	99	66.7	2.0
	900/1500	68	68	133	82.5	3.4
	2500	68	68	133	88.9	3.4
3/4	150	64	-	99	69.8	2.0
	300	64	68	133	82.5	3.4
	600	68	68	133	82.5	3.4
	900/1500	68	68	133	88.9	3.4
	2500	73	73	159	95.2	5.5
1	150	64	68	133	79.4	2.4
	300	64	68	133	88.9	3.4
	600	68	68	133	88.9	3.4
	900/1500	73	73	159	101.6	5.5
	2500	73	73	159	108.0	5.5
1 1/2	150	64	68	127	98.4	3.2
	300	69	69	159	114.3	5.5
	600	73	73	159	114.3	5.5
	900/1500	73	73	178	128.8	7.8
	2500	82	84	235	146.1	11.4
2	150	69	73	159	120.6	5.5
	300	69	75	178	127.0	7.8
	600	73	75	178	127.0	7.8
	900/1500	82	84	235	165.1	11.4

## Double Block & Bleed VMD Series

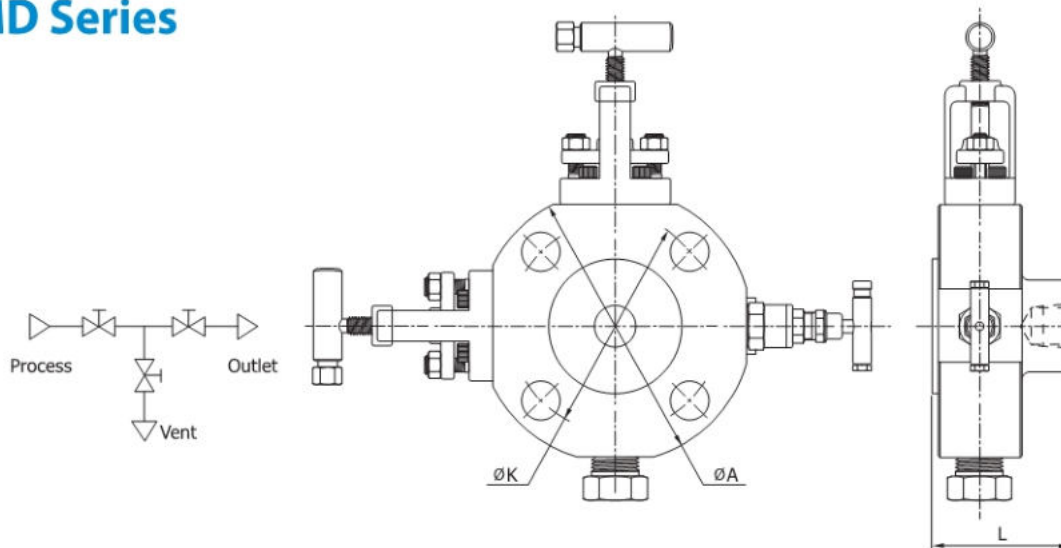

Size (inch)	Class	Dimensions(mm)				Weight (kg)
		L(RF)	L(RTJ)	A	K	
1/2	150	64	-	99	60.3	2.0
	300	64	68	99	66.7	2.0
	600	68	68	99	66.7	2.0
	900/1500	68	68	133	82.5	3.4
	2500	68	68	133	88.9	3.4
3/4	150	64	-	99	69.8	2.0
	300	64	68	133	82.5	3.4
	600	68	68	133	82.5	3.4
	900/1500	68	68	133	88.9	3.4
	2500	73	73	159	95.2	5.5
1	150	64	68	133	79.4	2.4
	300	64	68	133	88.9	3.4
	600	68	68	133	88.9	3.4
	900/1500	73	73	159	101.6	5.5
	2500	73	73	159	108.0	5.5
1 1/2	150	64	68	127	98.4	3.2
	300	69	69	159	114.3	5.5
	600	73	73	159	114.3	5.5
	900/1500	73	73	178	128.8	7.8
	2500	82	84	235	146.1	11.4
2	150	69	73	159	120.6	5.5
	300	69	75	178	127.0	7.8
	600	73	75	178	127.0	7.8
	900/1500	82	84	235	165.1	11.4

### Caution

Valves that have not been actuated for a period of time may have a higher initial actuation torque. Packing adjustment may be required during the valve in service.

# **DK-LOK**<sup>®</sup>

*Fittings & Valves*



## Safe Valve Selection

The selection of a valve for any application or system design must be considered to ensure safe performance. Valve function, valve rating, material compatibility, proper installation, operation and maintenance remain the sole responsibility of the system designer and the user. DK-Lok accepts no liability for any improper selection, installation, operation or maintenance.