



# Limit Switch Box



## Specifications

Item Type	
Switch Type	Mechanical Switch x2
Switch Rating	AC:250V 3A,125V 5A DC:250V 0.2A,125V 0.4A,30V 4A
Enclosure Protection	Weather proof, IP67 / NEMA4&4X
Ambient Temp.	-20°C~80°C
Conduit Entry	NPT1/2(PT1/2,PF1/2,M20,PG13.5)
Terminal	8Points
Mounting Bracket	NAMUR VDI / VDE 3845, ISO5211
Material	Aluminum
Weight	880g(1.94lb)

- Visual position indicator.
- Limit switch adjustment cams has spring. Changing cam position is very simple without requiring any tools. (close-up, open-down)
- Terminal strip number with 8 contacts is standard for micro-switches.
- Solenoid valve can be connected easily.
- Dual 1/2" conduit entries.
- It is designed to be captive by the cover.
- Can be mounted on any rotary actuator in ISO5211.

## Dimension

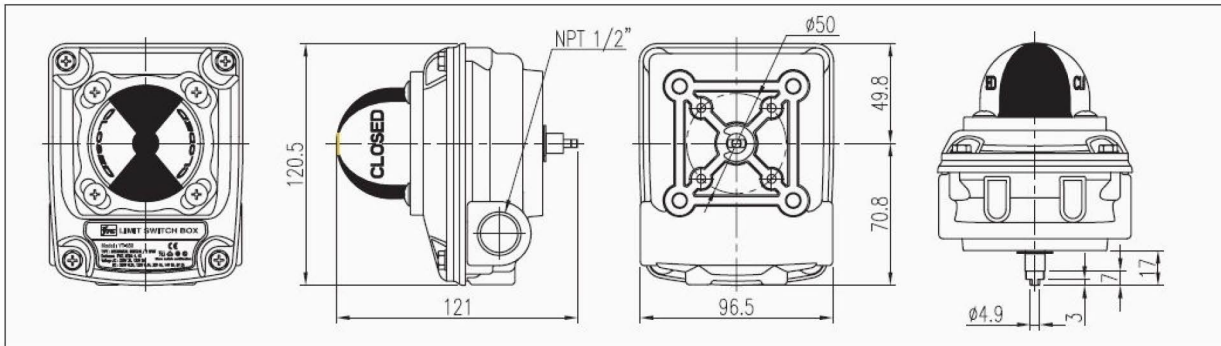

## Mounting Bracket

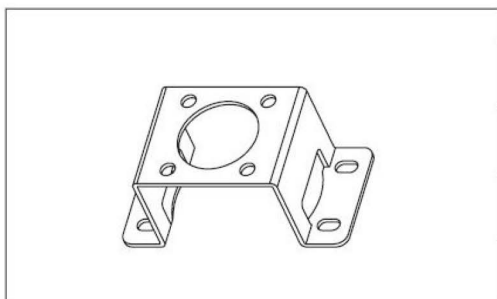

Model No.	Material	Application
-1	STAINLESS STEEL	30 * 130 , H : 30