



Butterfly valve DN 32 - 900

VALVE AND FLOW CONTROL SPECIALISTS
SERVICE AND RELIABILITY

Description

Centric butterfly valve plastomer lined for On/Off and control service for aggressive and corrosive fluids and high purity application

Product features

- Body construction B1 Wafer DN 32-600
B3 Lug DN 32-400
B4 U-section DN 450-900
- Face to face dimension according to ISO 5752/20, EN 558-1/20
- Top flange according to EN ISO 5211
- Max. working pressure 16 bar (DN32-150), 10 bar (DN200-300), 6 bar (DN350-700), 2,5 bar (DN750), 6 bar (DN800-900)
- Rating PN10, PN16, ANSI cl. 150
- Temperature range -20°C ÷ 200°C according to working conditions, other temperatures on request
- Work's tests Porosity check of the liner and overmolded disc according to DIN EN 60243-1. Test certificates on request. Tightness test according to EN 12266-1/P12 leakage rate A.

The torque of each valve is registered.

The butterfly valves meet the safety requirements of the pressure Equipments Directive 97/23/EC (PED) appendix 1 for fluids of the groups 1 and 2.

Butterfly valves are suitable to be operated in safety related systems according to IEC 61508 / 61511, Safety Integrity Level SIL 2

Special versions of the valves may be used in explosive atmospheres. See brochure ATEX.

VDI 2440 as option



TA-Luft

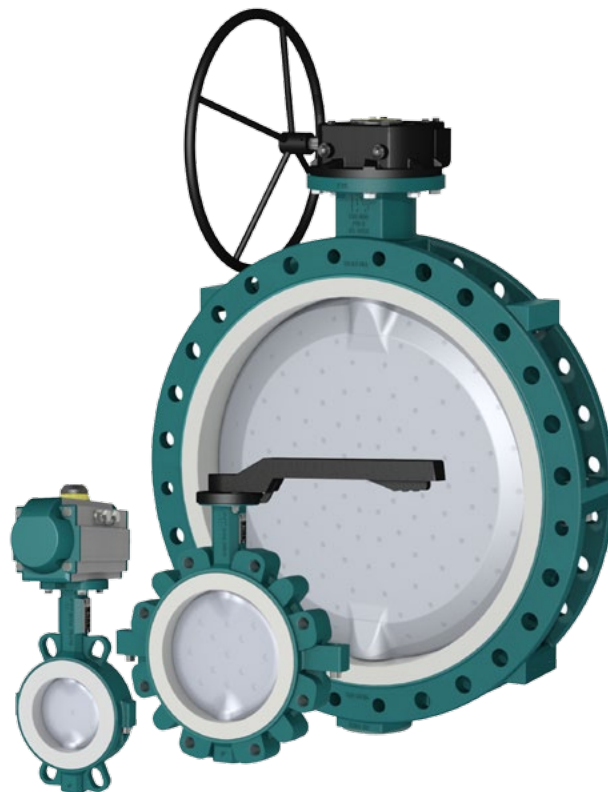

B1
Wafer



B3
Lug

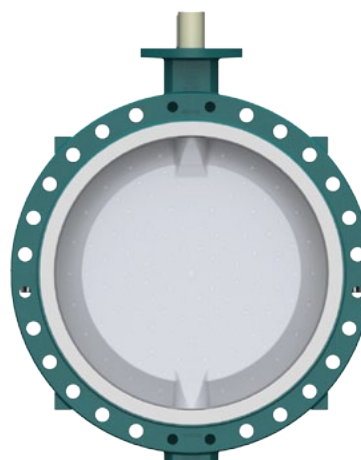

B4
U-section

Construction

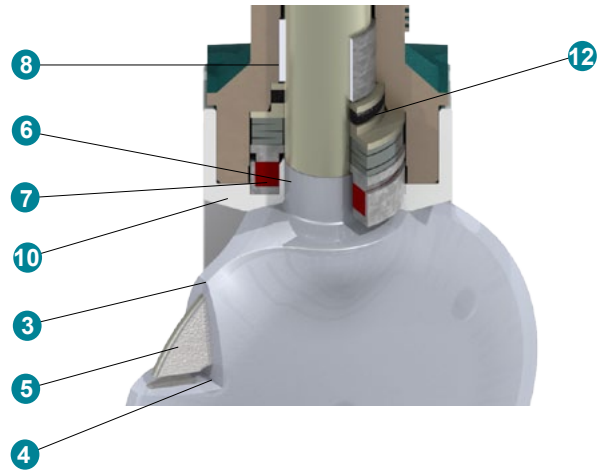
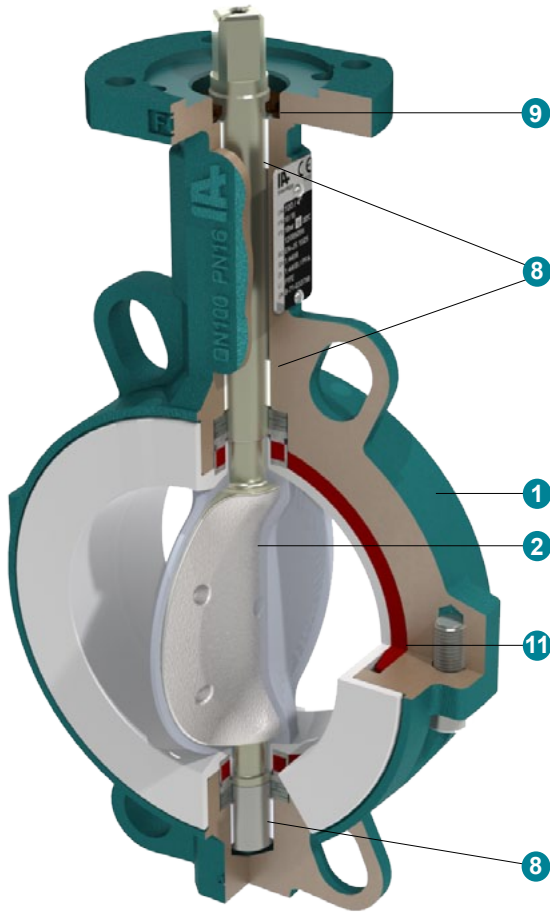

1	Two-piece body in GGG 40.3 / EN-GJS-400-18-LT
2	One-piece, blow out proof disc/shaft
3	Overmolding with a min. thickness of 3 mm
4	Overmolding is mechanically locked on the disc
5	Thin core, allows high k_v flow rate
6	Shaft overmolded in the shaft sealing area
7	Shaft sealing by prestressed safety packing
8	Self-lubricating shaft bushing
9	External shaft sealing
10	Chambered liner, prevents radial cold-flow
11	Elastomer back-up, immersed in body
12	TA-Luft VDI 2440 packing as option

Torques with PTFE liner, security factor included

DN	32/40	50	65	80	100	125	150	200	250	300	350	400	450	500	600	700	750	800	900
Nm	21	25	39	43	73	87	146	189	330	476	675	900	1100	1300	1750	2100	2500	3100	4000



Type code

B1	0100	3	3	2BE	4GT	TS	xx
1	2	3	4	5	6	7	8

1 Body type	B1	Wafer	DN32-600
	B3	LUG body	DN32-400
	B4	U-section body	DN450-900
2 Nominal diameter	0032-0900	mm	
3 Working pressure	0	2,5 bar	DN750
	1	6 bar	DN350-700, DN800-900
	2	10 bar	DN200-300
	3	16 bar	DN32-150
4 Rating	**	PN10/16/ANSI B16.5 cl150 see table below	
5 Body	2BE	Ductile iron EN-JS 1025 (GGG40.3), Epoxy coated 80µ	
	3HE	Cast steel 1.0619, Epoxy coated 80µ	DN32-300 (on request)
	4B0	Stainless steel 1.4409	DN32-300
6 Disc-shaft, one piece	4G0	Stainless steel 1.4408	DN32-300
		Stainless steel 1.4404	DN350-900
	4GP	Stainless steel 1.4408 polished Ra < 0,8	DN32-300
		Stainless steel 1.4404 polished Ra < 0,8	DN350-900
	4GJ	Stainless steel 1.4435, Ferrite < 1%, e-polished Ra < 0,4	DN32-300
	4GT	Stainless steel PFA coated	DN32-300 (>300 on request)
	3BT	Disc carbon steel PFA coated, shaft stainless steel	DN350-900
	**A	PFA antistatic	
	4D0	Uranus 1.4539	(on request)
	7H0	Hastelloy 2.4602	(on request)
7T0	Titan 3.7035, Gr2	(on request)	
7 Liner / backup	TS	PTFE / MVQ	
	TE	PTFE / EPDM	
	TV	PTFE / FPM	
	**V	ULTRAFロン® (UF) for Vacuum or Chlorine applications	
	**A	PTFE or ULTRAFロン® antistatic	
8 Special execution	LF	without painting adhesion interfering substance	
	HP	High purity: The valve is cleaned, mounted, proofed and packed under cleanroom conditions. (US federal standard 209b, class 10000)	
		ATEX execution see brochure ATEX	
	180	TA-Luft VDI 2440	

Other executions on request !

**Rating (Code)

		DN →	32	40	50	65	80	100	125	150	200	250	300	350	400	450	600	600	700	750	800	900		
	B1	PN10	3										2											
		PN16	3										3											
		ANSI cl.150		3										A										
	B3	PN10	3										2											
		PN16	3										3											
		ANSI cl.150		A																				
	B4	PN10															2					2		
		PN16															3					3		
		ANSI cl.150															A							

When mounting the valve at the end of a line please note:

- Body type **Lug B3**
- Temperature 10 ÷ 60°C
- Medium only for non hazardous liquids
- no water hammer !
- Max. working pressure DN32-150 8 bar
- DN200-300 6 bar
- DN350-400 4 bar

Dimensions

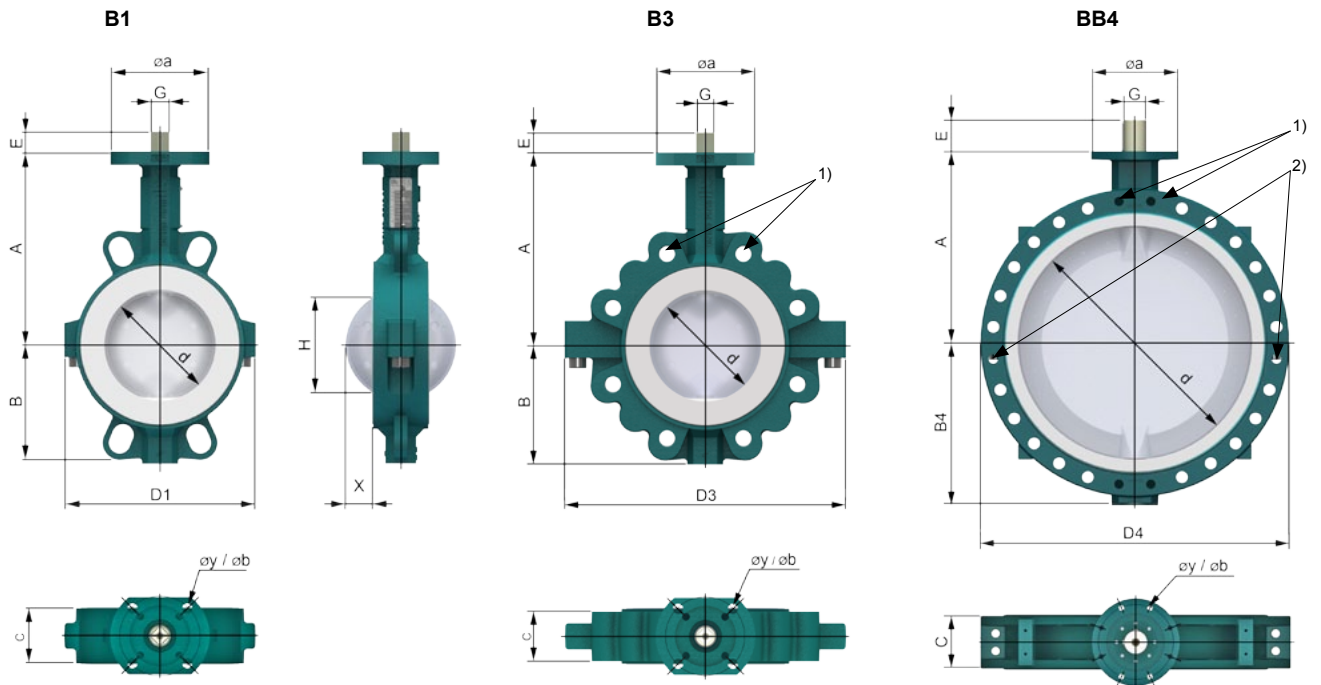

1) DN 450 - 900, 2 x threads on valve neck and bottom
2) DN 600 - 900, 2 threads on both sides

DN	d	A	B	B4	C	H	X	D1	D3	D4	ISO	a	y	b	G	E	B1[kg]	B3[kg]	B4[kg]
32/40	40	125	69	-	33	23	4	105.8	136	-	F05	65	4x7	50	11	19	1.7	2.4	-
50	50	134	68	-	43	26	9	118.4	162	-	F05	65	4x7	50	11	19	2.3	3.2	-
65	65	145	78	-	46	39	7	132.5	170	-	F05	65	4x7	50	11	19	2.9	4.1	-
80	80	160	92	-	46	66	17	144	216	-	F05	65	4x7	50	11	19	3.4	6.2	-
100	100	175	107	-	52	86	24	173	254	-	F05/07	90	4x7/9	50/70	14	19	5.1	9.3	-
125	125	194	120	-	56	112	35	219	293	-	F05/07	90	4x7/9	50/70	14	19	6.9	10.7	-
150	150	210	134	-	56	140	47	247	315	-	F07	90	4x9	70	17	25	10	12.9	-
200	200	239	162	-	60	191	70	295	389	-	F07/F10	125	4x9/11	70/102	17	25	14.1	22.3	-
250	250	275	199	-	68	241	91	367	483	-	F10	125	4x11	102	22	32	22.9	32.4	-
300	300	310	230	-	78	290	111	419	543	-	F10	125	4x11	102	22	32	32.9	46.9	-
350	339	349	254	-	78	330	131	428	564	-	F12	155	4x 13.5	125	27	40	50	87	-
400	400	379	287	-	102	387	149	473	620	-	F12	155	4x 13.5	125	27	42	68	98	-
450	450	426	320	320	114	436	168	528	-	630	F14	175	4x 18	140	Ø45	65	100	-	140
500	500	451	360	360	127	484	187	588	-	700	F14	175	4x 18	140	Ø45	65	122	-	175
600	600	555	415	415	154	580	223	686	-	820	F16	210	4x 22	165	Ø60	90	180	-	275
700	703	605	-	482	165	684	269	-	-	930	F16	210	4x 22	165	Ø72	80	-	-	423
750	750	629	-	489	190	726	280	-	-	970	F16	210	4x 22	165	Ø60	91	-	-	383
800	803	658	-	550	190	781	307	-	-	1060	F25	300	8x 18	254	Ø80	108	-	-	670
900	900	710	-	602	203	877	349	-	-	1160	F30	350	8x 22	298	Ø98	128	-	-	880

Dimensions X and H are without safety!

The customer must define safety distances to secure accurate installation of the valve.

Dimensions

Gearbox

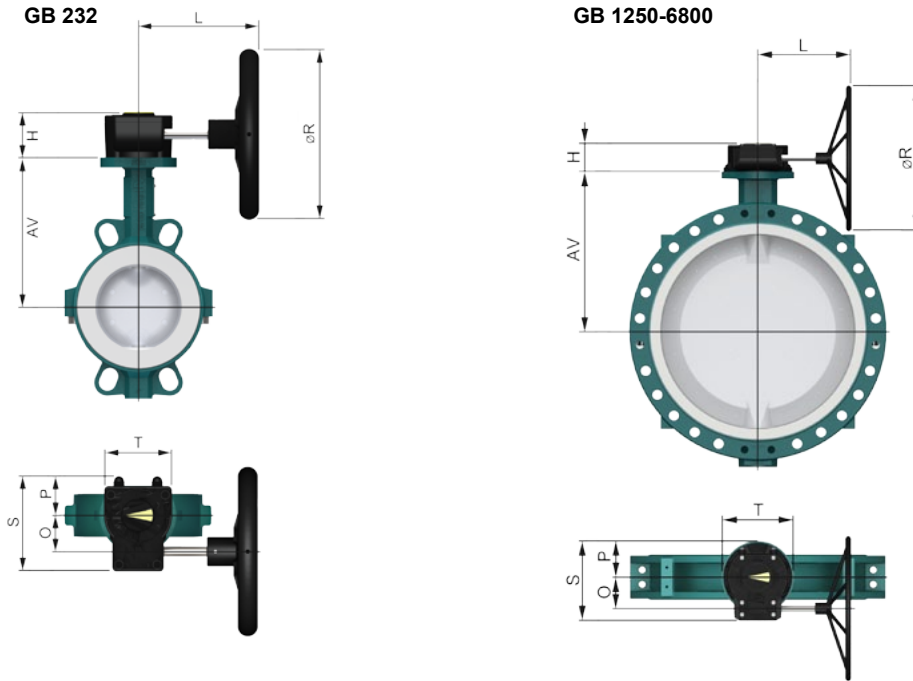

DN		AV	H	L	O	P	R	S	T	n**	[kg]*
32/40	GB232-05.F05-F0711.100	125	53	121	42.5	48	100	114	80	10	0.8
50	GB232-05.F05-F0711.100	134	53	121	42.5	48	100	114	80	10	0.8
65	GB232-05.F05-F0711.100	145	53	121	42.5	48	100	114	80	10	0.8
80	GB232-05.F05-F0711.100	160	53	121	42.5	48	100	114	80	10	0.8
100	GB232-05.F05-F0714.100	175	53	121	42.5	48	100	114	80	10	0.8
125	GB232-05.F05-F0714.100	194	53	121	42.5	48	100	114	80	10	0.8
150	GB232-06.F05-F0717.160	210	59	179	42.5	48	160	114	80	10	0.9
200	GB232-06.F07-F1017.160	239	59	179	42.5	48	160	114	80	10	0.9
250	GB232-08.F07-F1022.250	275	67	209	50	56	250	131	100	9.25	1.55
300	GB232-08.F07-F1222.250	310	67	209	50	56	250	131	100	9.25	1.55
350	GB232-13.F10-F1227.400	350	84	376	80	83	400	209	175	10	5.4
400	GB232-13.F10-F1227.500	380	84	396	80	83	500	209	175	10	5.4
450	GB232-14.F1445.500	426	84	396	80	83	500	209	175	10	5.4
500	GB232-14.F1445.600	451	84	396	80	83	600	209	175	10	5.4
600	GB1250N.F1660.500	555	102	346	104.5	110	500	258	220	13.75	22
700	GB1950N.F1672.700	605	126	391	130	142.5	700	322.5	285	13	32
750	GB1950N.F1660.700	630	126	391	130	142.5	700	322.5	285	13	32
800	GB2000NLB.F2580.500	658	121	348	53	106	500	293	285	27	27
900	GB6800NPR4.F3098.400	710	159	450	182	170	400	407	370	81	62.5

Material: GB 232 Aluminium, Polyurethane coated
GB1250-GB6800 GG 25 Polyurethane coated

* [kg] weight without butterfly valve and handwheel

** n = Handwheel turns ON/OFF