

A Long Experience in Energy Equipment and one Goal:

The Customer's satisfaction.

Delta Valves Europe



Lubricated Plug Valves Type 20 & 21

DELTA
VALVES EUROPE



Valve and Flow Control Specialists Pty Ltd
Melbourne Sydney Brisbane Darwin
AUSTRALIA
sales@valveandflowcontrolspecialists.com



Some useful news concerning Lubricated Plug Valves Material /Costruction.

In order to meet with Int'l Specifications and various Customers' needs, Delta Valves Europe (DVE) is producing Lubricated Plug Valves suitable to cover the widest applications.

Executions

- Lubricated Inverted Taper Pressure Balanced High Performance Plug Valves.
- Lubricated Inverted Taper Pressure Balanced High Performance



Materials Application.

All DVE Products are normally available in:

- Standard Carbon Steel which are supplied in 0,22% MAX Carb. contents, and destined to General Service at Temperatures from - 29° C Up to + 232° C (- 20° F% + 450° F). Plugs are normally in Carbon Steel too, in Hardened Condition.
- Low Temperature Service Suitable from - 46° C to + 232° C (- 50° F% + 450° F). Normally used for Below Zero. Temperatures to - 46° C must have a Minimum Average Charpy "V" Notch Impact Strength a/15 Foot/Lb.
- In Natural Gas it is Possible to encounter small amounts of Hydrogen Sulfides (H₂S) which may cause corrosion. This phenomenon is normally known as "Hydrogen Sulfide Embrittlement" or "Sulfide Stress Cracking". The Absorbtion of Hydrogen from Part of the Steel Causes Ductility which, when added to other elements of stress given by the service itself, may originate failure of the forged or cast component. Steels with Yield Strengths

- above 621 Mpa (90.000 PSI) or with Hardness over 22 Rockwell (235Brinell) may be subject to "Sulfide Stress Cracking". In Nace MR01.75-88 Construction DVE is carefully checking that all basic material componentes are propely treated in order to remain below the Hardness of 22 Rockwell. In such a case, plugs are property Electro Nickel Coated to prevent galling action.
- Stainless Steel material which contains Molybdenum and suitable for service temperature from + 232° C to + 371° C (+ 450° of % 700° F) normally used for Valves destined to High Temperature Service or where High Corrosion resistance is needed.
- 13% Chr. - 316 - Monel (Solid or Coating) Stellite No.6 (Coating)
- Special material available on request.



Lubricated Steel Plug Valves Pressure Balanced Inverted Type.

These valves are installed where existing pulsant or static high pressures are present. The benefit which a pressure balanced Plug gives is the equalized pressure between the Plug and upper and lower body chambers. Pressure is balanced by two holes in the Plug connecting the Plug port with lower and upper cavities.

The hole in the lower end is a simple connecting passage whilst the hole in the upper end is provided with a check valve so the pressure is always equal to the one in the large end cavity and it is always equal to or greater than the line pressure in the small end cavity. Some advantages are:

- Easy maintenance even after a long time in open/closed position
- In case of locking of the Plug with the body, it is possible to release by injecting lubricant through the greaser with the valve in service
- Tightness of the stem is assured by an antifriction ring fitted between the stem and body. Two gaskets fitted between the stem and valve body guarantee against any leakage through the stem.
- Tightness of the operating system is assured by the ball check devices on the lubrication duct. An additional check valve is put into the lubrication duct.
- When required the valve is equipped with double operating grease injectors suitable for a lubricating gun and lubricating sticks.

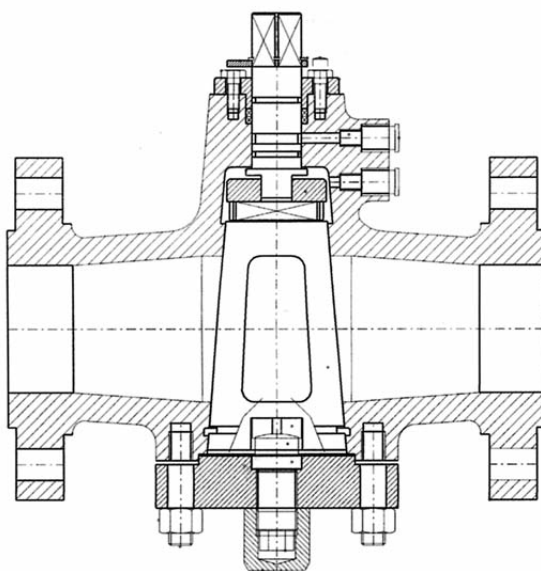

Gear Operated

Wrench Operated

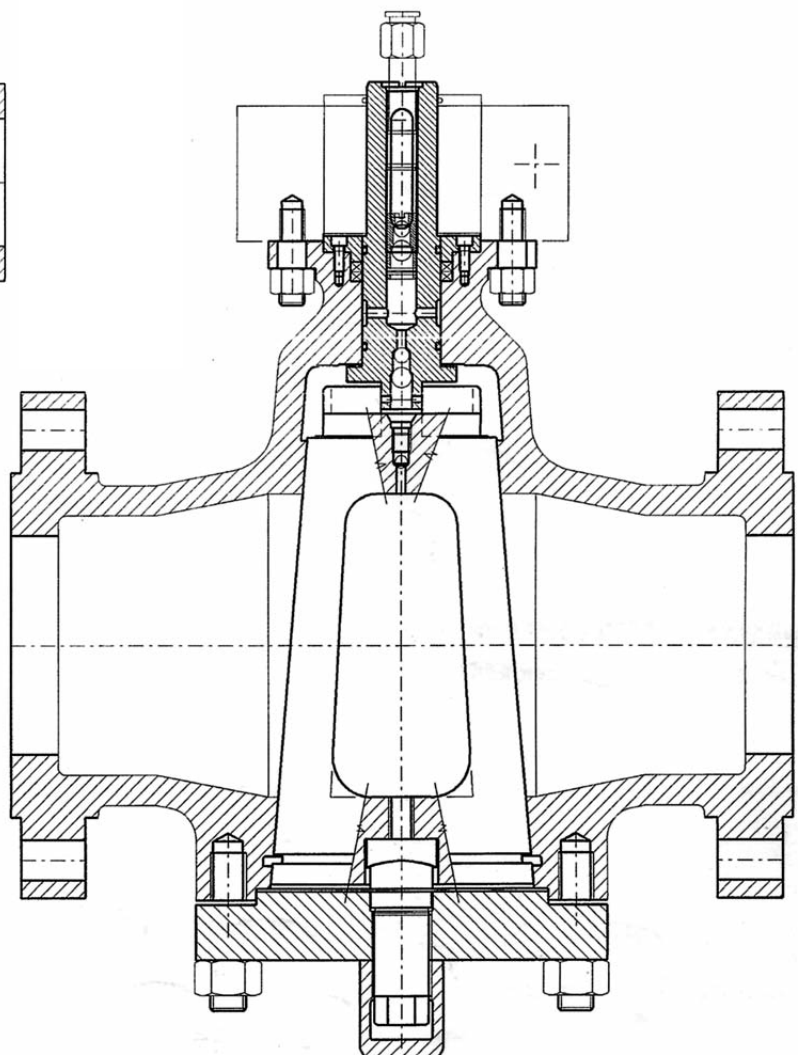

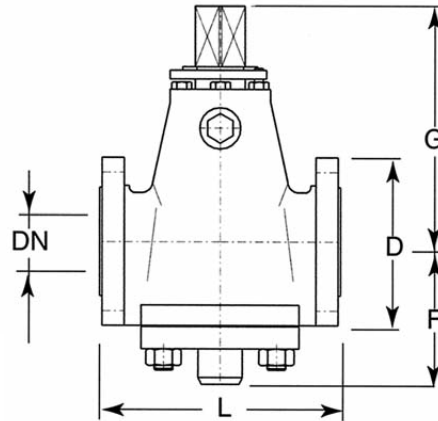

**Short Pattern
Wrench Operated**

Size DN	Inch mm	1 1/2 15	2 50	2 1/2 65	3 80	4 100	6 150
L RF	mm	165	178	190	203	229	267
L RJ	mm	-	191	203	216	242	280
L BW	mm	-	267	305	330	356	457
D	mm	127	152	178	191	229	280
F	mm	120	130	150	170	190	235
G	mm	270	290	320	360	380	460
J \varnothing	mm	40	45	50	50	50	65
Weight (approx)	Kg	15	20	30	40	60	110

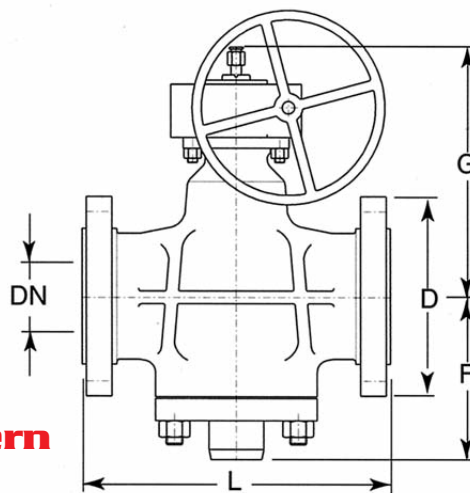

**Short & Venturi Pattern
Gear Operated**

Size DN	Inch mm	6 150	8 200	10 250	12 300	14 350	16 400	18 450	20 500	22 550	24 600	30 750
L RF	mm	267	292	330	356	686	762	864	914	1030	1067	1296
L BW	mm	457	521	559	635	686	762	864	914	1030	1067	1397
D	mm	280	343	406	483	534	597	635	699	750	813	984
F	mm	240	260	280	300	330	350	380	410	460	500	580
G	mm	480	510	530	550	600	620	640	700	750	800	900
Handwheel diameter	mm	500	500	650	650	650	650	650	650	800	800	800
Weight (approx)	Kg	135	170	230	350	460	700	880	1050	1500	2030	3000

Class 300

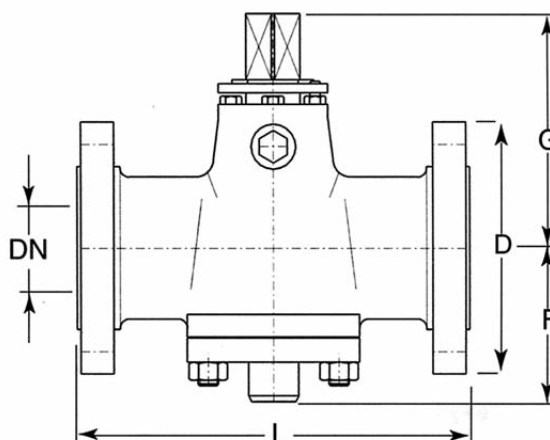

Short Pattern Wrench Operated

Size DN	Inch mm	1 1/2 15	2 50	2 1/2 65	3 80	4 100	6 150
L RF	mm	190	216	241	283	305	403
L RJ	mm	203	232	257	299	321	419
L BW	mm	-	267	305	330	356	457
D	mm	156	165	191	210	254	318
F	mm	115	140	150	170	180	235
G	mm	250	290	310	360	380	460
J ∅	mm	40	45	50	50	50	65
Weight (approx)	Kg	20	25	35	50	76	140

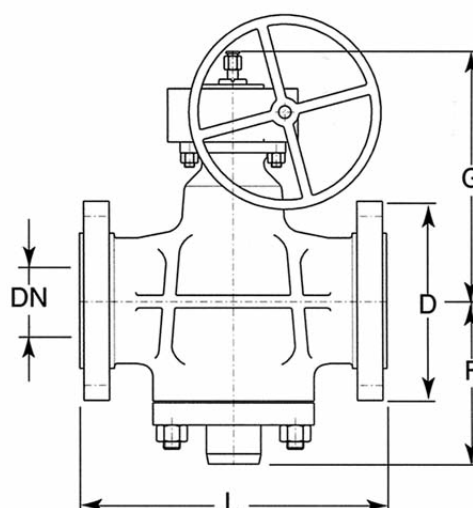

Venturi Pattern Gear Operated

Size DN	Inch mm	6 150	8 200	10 250	12 300	14 350	16 400	18 450	20 500	22 550	24 600
L RF	mm	403	419	457	502	762	838	914	991	1092	1143
L RJ	mm	419	435	473	518	778	854	930	1010	1114	1165
L BW	mm	457	521	559	635	762	838	914	991	1032	1143
D	mm	318	381	445	521	584	648	711	775	838	915
F	mm	240	260	280	300	350	370	400	430	480	530
G	mm	500	530	550	570	620	640	700	750	820	900
Handwheel diameter	mm	650	650	650	650	650	650	800	800	800	800
Weight (approx)	Kg	190	250	285	385	630	800	1000	1200	1500	2200

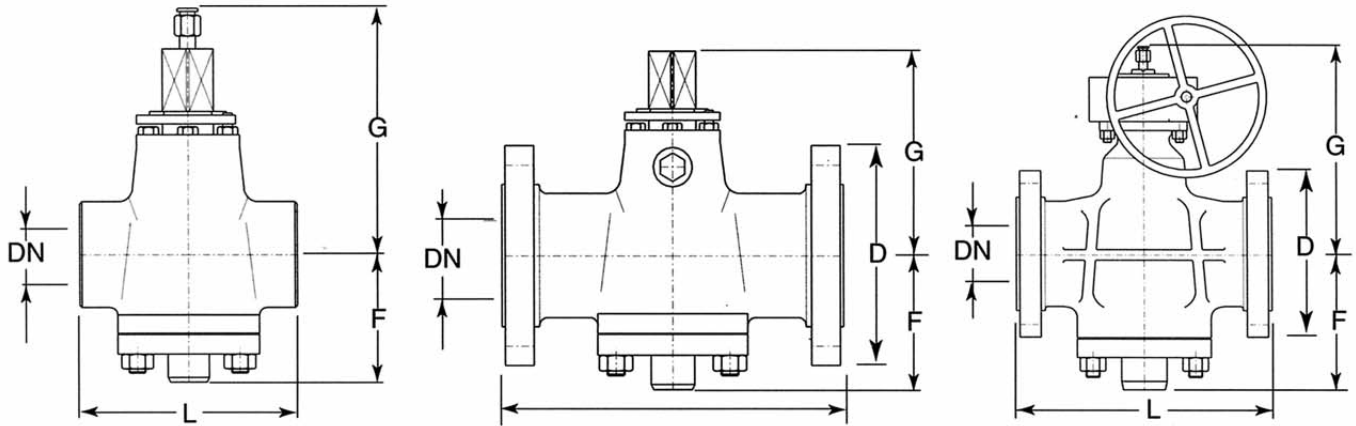

**Regular Pattern
Wrench Operated**

Size DN	Inch mm	1/2 15	3/4 20	1 25	1 1/2 40	2 50	2 1/2 65	3 80	4 100	6 150
L RF	mm	165	191	216	241	292	330	356	406	495
L BW	mm	165	191	216	241	242	330	356	406	495
D	mm	95	118	124	156	165	141	210	254	318
F	mm	85	85	95	110	120	130	140	170	230
G	mm	170	170	180	195	235	260	310	350	460
J ☐	mm	25	29	35	40	45	50	50	50	65
Weight (approx)	Kg	16	18	22	25	30	40	65	105	180

**Venturi Pattern
Gear Operated**

Size DN	Inch mm	6" 150	8 200	10 250	12 300	14 350	16 400	18 450	20 500	24 600
L RF	mm	495	597	673	762	826	902	978	1054	1232
L BW	mm	495	597	673	762	826	902	978	1054	1232
D	mm	318	381	445	521	584	648	711	775	914
F	mm	500	530	550	570	620	640	700	750	900
G	mm	230	260	280	300	350	370	400	430	530
J ☐	mm	650	650	650	650	650	650	800	800	800
Weight (approx)	Kg	200	260	300	410	660	820	1030	1250	2320

Class 600

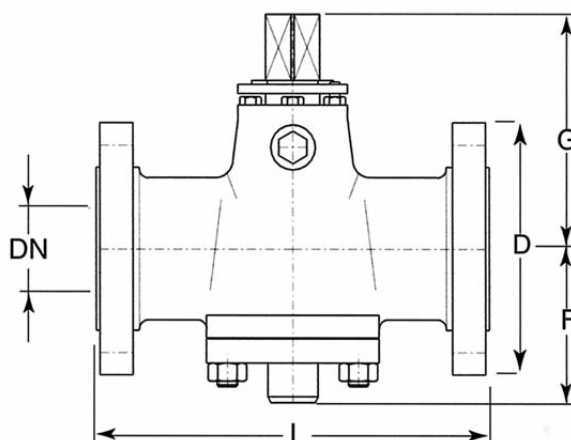

Regular Pattern Wrench Operated

Size DN	Inch mm	1/2 15	3/4 20	1 25	1 1/2 40	2 50	2 1/2 65	3 80	4 100
L RF	mm	159	191	216	241	292	330	356	432
L RJ	mm	159	191	216	241	295	333	359	435
L BW	mm	-	-	216	241	292	330	356	432
D	mm	95	118	121	156	165	191	210	273
F	mm	100	120	120	140	140	150	160	185
J ☐	mm	22	27	27	40	45	50	50	50
G	mm	160	200	200	270	290	320	360	380
Weight (approx)	Kg	7	11	13	26	30	45	65	90

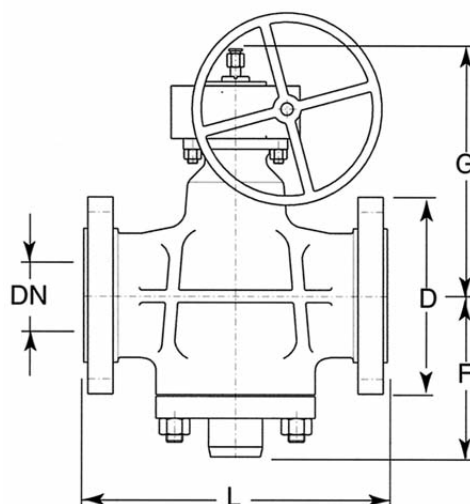

Regular and Venturi Pattern Gear Operated

Size DN	Inch mm	4 100	6 150	8 200	10 250	12 300	14 350	16 400	18 450	20 500	22 550	24 600
L RF	mm	432	559	660	787	838	889	991	1092	1194	1296	1397
L RJ	mm	435	562	663	790	841	892	994	1095	1200	1305	1407
L BW	mm	432	559	660	787	838	889	991	1092	1194	1296	1397
D	mm	273	356	419	508	559	603	686	743	813	870	940
F	mm	185	243	260	280	300	350	370	400	430	500	521
G	mm	380	520	550	570	580	610	625	700	750	830	900
Handwheel diameter	mm	500	500	650	650	650	650	650	800	800	800	800
Weight (approx)	Kg	135	210	390	550	680	860	1100	1550	2000	2500	3200

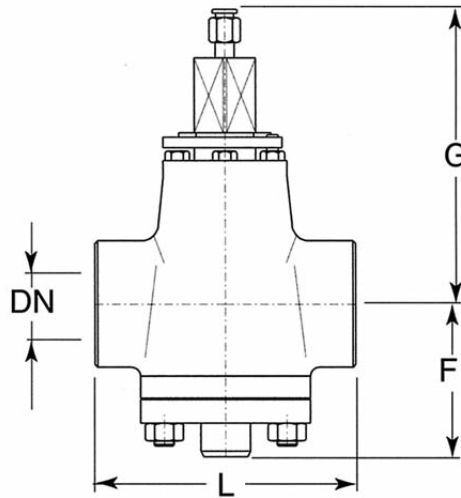

**Screwed or
Socket Weld Ends
Wrench Operated**

Size DN	Inch mm	1/4 8	3/8 10	1/2 15	3/4 20	1 25	1 1/2 40	2 50
L	mm	89	89	89	114	133	187	229
F	mm	90	90	95	95	100	118	132
G	mm	145	145	145	145	210	280	300
J ∅	mm	22	22	22	22	27	40	45
Weight (approx)	Kg	4	4	5	5	9	17	26

Class 800

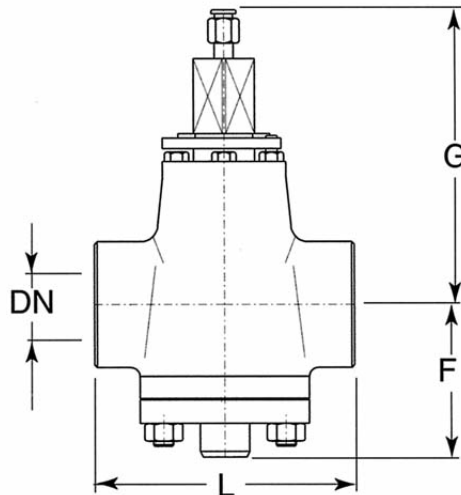

**Screwed or
Socket Weld Ends
Wrench Operated**

Size DN	Inch mm	1/4 8	3/8 10	1/2 15	3/4 20	1 25	1 1/2 40	2 50
L	mm	89	89	89	114	133	187	229
F	mm	90	90	95	95	100	118	132
G	mm	145	145	145	145	210	280	300
J ∅	mm	22	22	22	22	27	40	45
Weight (approx)	Kg	4	4	5	5	9	17	26

Class 900

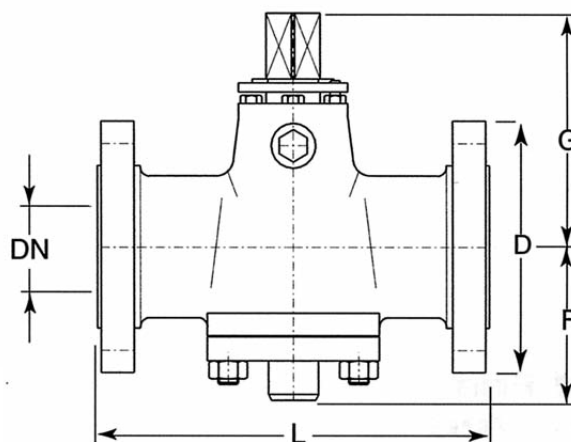

Regular Pattern Wrench Operated

Size DN	Inch mm	1/2 15	3/4 20	1 25	1 1/2 40	2 50	3 80	4 100
L RF	mm	222	248	254	305	368	381	457
L RJ	mm	222	248	254	305	372	384	460
L BW	mm	-	-	-	-	-	381	457
D	mm	121	130	149	178	216	241	292
F	mm	100	100	100	140	140	150	200
G	mm	150	180	200	280	300	360	380
J \square	mm	22	27	27	40	45	50	50
Weight (approx)	Kg	10	15	20	34	65	90	120

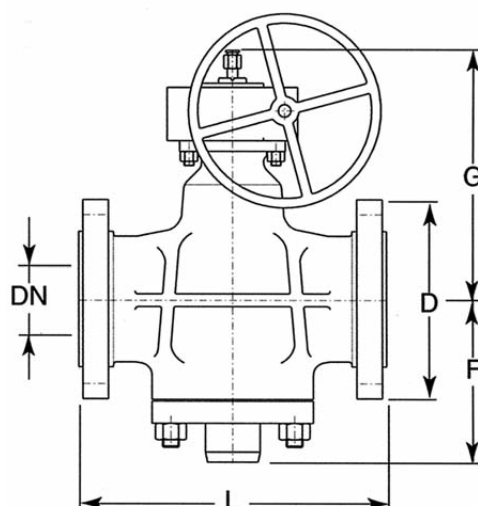

Regular and Venturi Pattern Gear Operated

Size DN	Inch mm	4 100	6 150	8 200	10 250	12 300	14 350	16 440	20 500
L RF	mm	457	610	737	838	965	1028	1130	1321
L RJ	mm	460	613	740	841	968	1038	1140	1324
L BW	mm	452	610	737	838	965	1028	1130	1321
D	mm	292	381	470	546	610	641	705	857
F	mm	200	250	300	320	355	370	80	400
G	mm	410	510	540	580	660	660	680	700
Handwheel diameter	mm	500	600	650	650	800	800	800	800
Weight (approx)	Kg	145	320	480	760	1280	1500	1650	2500

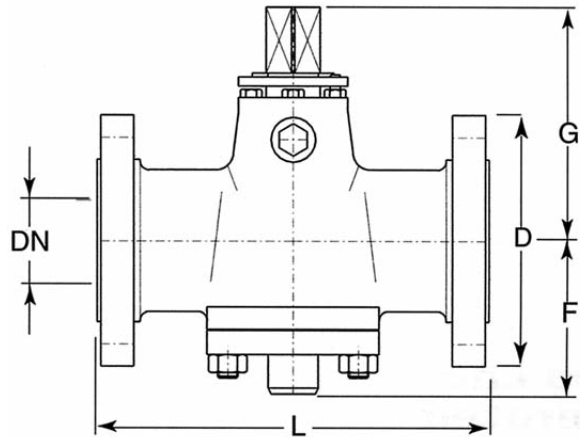

**Regular Pattern
Wrench Operated**

Size DN	Inch mm	1/2 15	3/4 20	1 25	1 1/4 32	1 1/2 40	2 50	2 1/2 65	3 80
L RF	mm	222	248	254	279	305	368	419	470
L RJ	mm	222	248	254	279	305	371	422	473
L BW	mm	-	-	-	-	-	-	-	470
D	mm	121	130	149	159	178	216	245	267
F	mm	100	100	100	120	130	150	160	170
G	mm	160	200	200	250	270	390	320	360
J \varnothing	mm	22	27	27	35	40	45	50	50
Weight (approx)	Kg	11	15	20	24	36	55	80	100

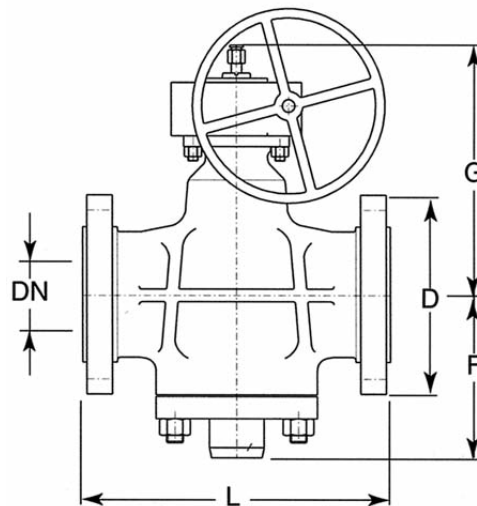

**Regular and
Venturi Pattern
Gear Operated**

Size DN	Inch mm	3 80	4 100	6 150	8 200	10 250	12 300
L RF	mm	470	546	705	832	991	1130
L RJ	mm	473	549	711	842	1001	1146
L BW	mm	470	546	705	832	991	1130
D	mm	267	311	394	483	584	673
F	mm	150	210	260	300	360	460
G	mm	390	400	500	540	580	650
Handwheel diameter	mm	500	500	650	650	800	800
Weight (approx)	Kg	130	220	550	1100	1350	1900

Class 1500

**Screwed or
Socket Weld Ends
Wrench Operated**

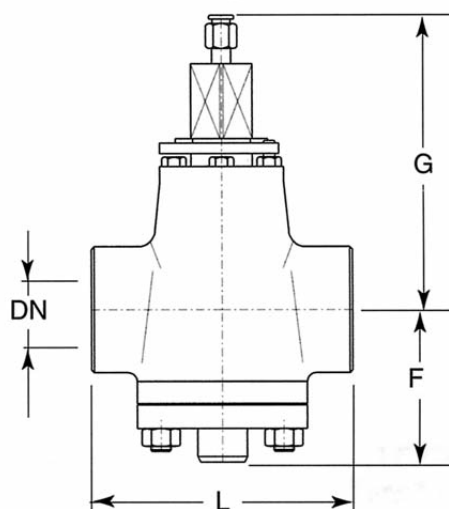

Size DN	Inch mm	3/8 10	1/2 15	3/4 20	1 25	1 1/2 40	2 50
L	mm	89	89	114	133	229	229
F	mm	95	95	95	100	125	135
G	mm	145	145	145	210	280	300
J \varnothing	mm	22	22	22	27	40	45
Weight (approx)	Kg	5	5	5	9	21	30

Class 2500

**Screwed or
Socket Weld Ends
Wrench Operated**

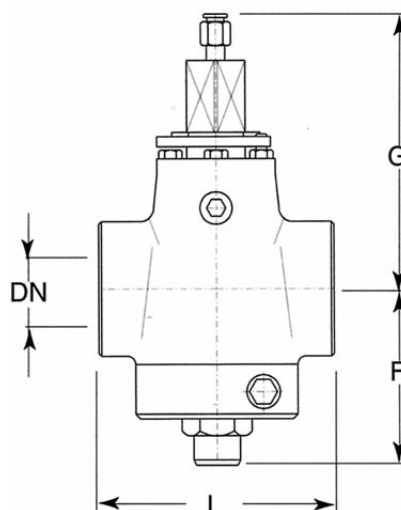

Size DN	Inch mm	1/2 15	3/4 20	1 25
L	mm	133	133	133
H	mm	150	150	150
G	mm	240	240	240
J \varnothing	mm	32	32	32
Weight (approx)	Kg	16	18	18

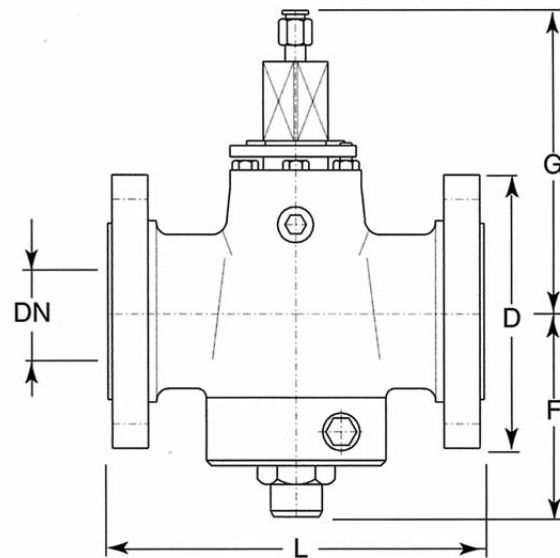

**Regular Pattern
Wrench Operated**

Size DN	Inch mm	1 25	1 1/2 40	2 50	2 1/2 65
L RF	mm	308	384	451	508
L RJ	mm	308	387	454	514
L BW	mm	308	384	451	508
D	mm	159	203	235	267
F	mm	150	165	175	190
G	mm	240	240	260	280
J \square	mm	32	45	50	50
Weight (approx)	Kg	32	68	85	110

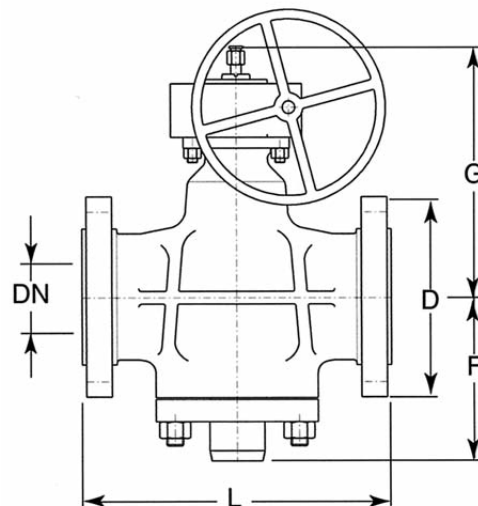

**Regular Pattern
Gear Operated**

Size DN	Inch mm	3 80	4 100	6 150	8 200
L RF	mm	-	673	914	1022
L RJ	mm	-	683	927	1038
L BW	mm	578	673	914	1022
D	mm	305	356	483	552
F	mm	200	220	260	310
G	mm	410	425	470	510
Handwheel diameter	mm	500	650	800	800
Weight (approx)	Kg	165	230	660	1250

Extension Stem for Wrench and Gear Operated Lubricated Plug Valve for buried Installation.

Extended stems are made to be installed on Wrench Operated standard stems, in case of buried installation of the Plug Valve or in case of installation of the valve in plant locations where a normal access of manouvre is not possible. Valve extension for underground service include piping for lubrication and are supplied with water tight seals. Extension length should be advised by customer.

As already described in case of Wrench Operated Valves, these extesions are suitable for Plug valves with gear operators. The extension stem is similar to the previous one. The position of the Plug is indicated by an indicator on the top of the gear box.

Valve extension for underground service include piping for lubrication and are supplied with water tight seals. Extension length should be advised by customer.

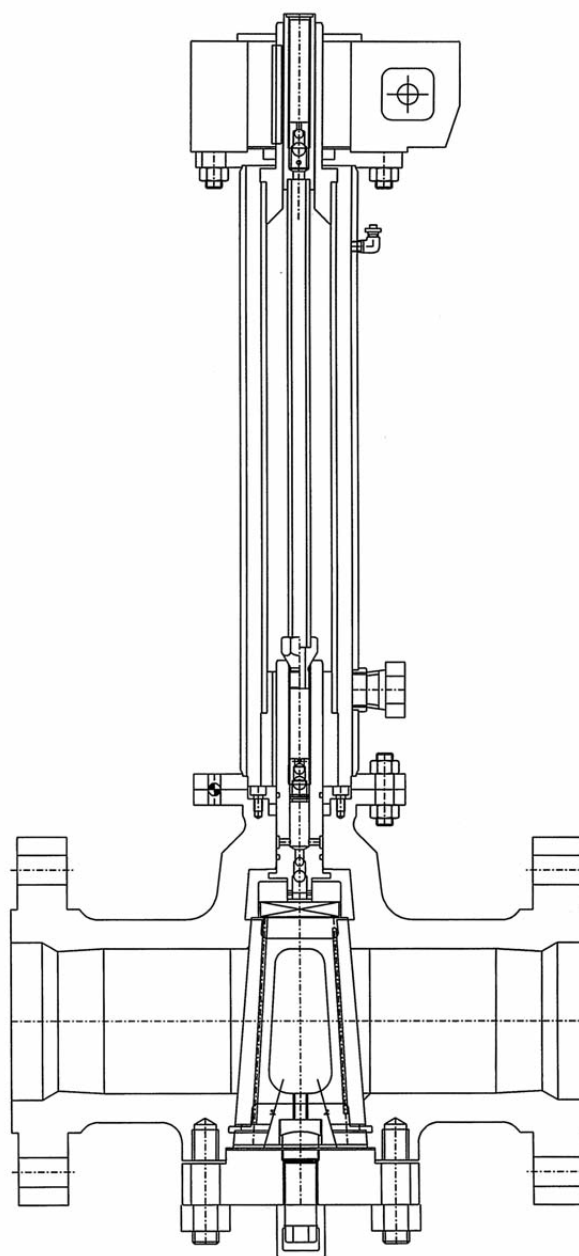
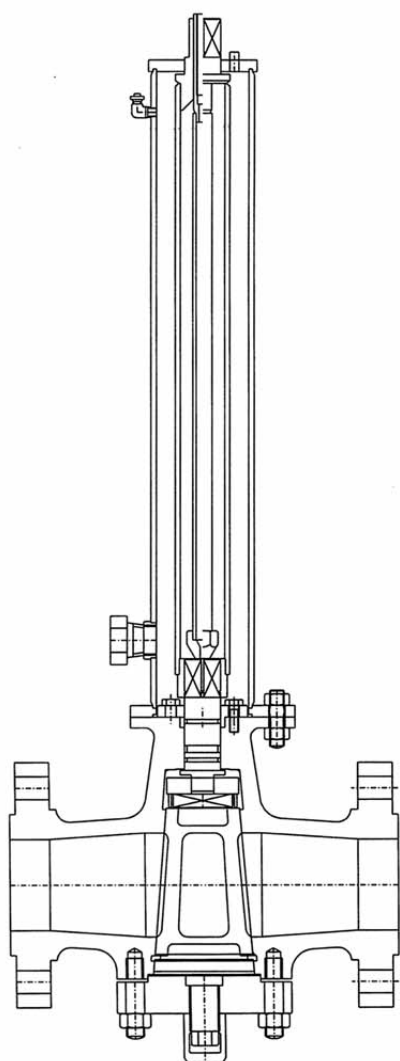

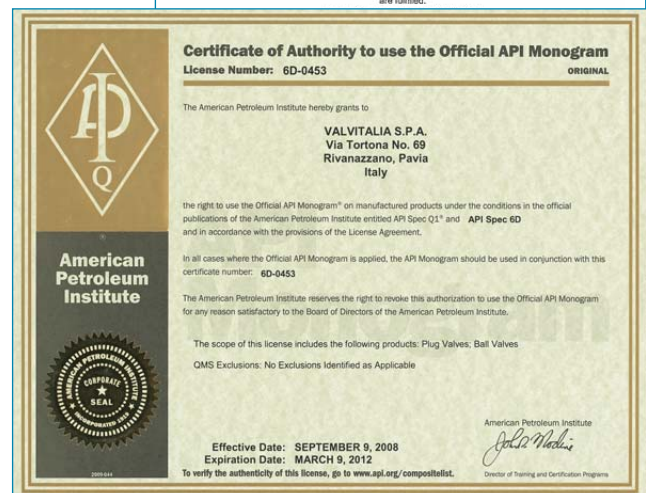

A Long Experience in Energy Equipment and one Goal:

The Customer's satisfaction.



Valve and Flow Control Specialists Pty Ltd
Melbourne Sydney Brisbane Darwin
AUSTRALIA
sales@valveandflowcontrolspecialists.com