

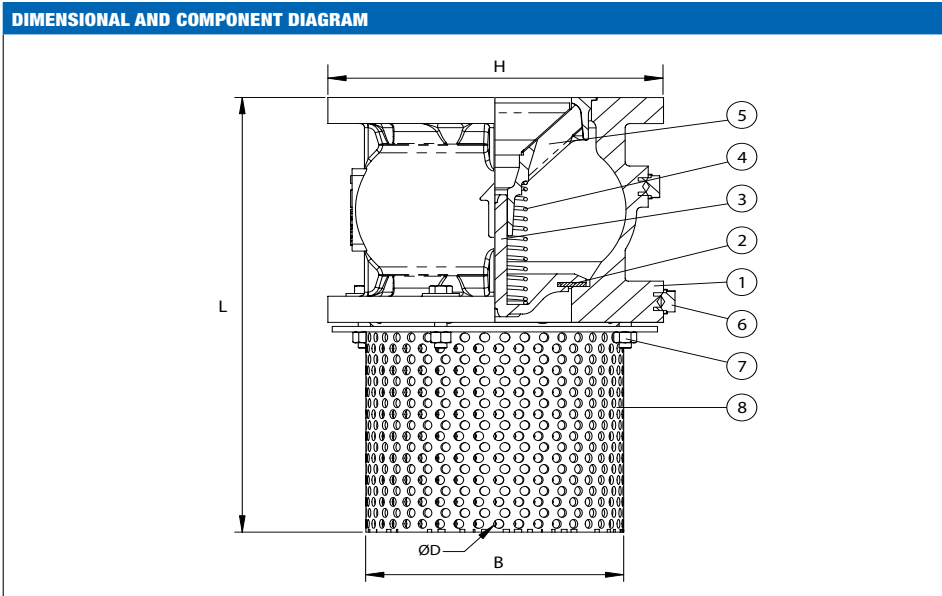

## CAST IRON FOOT VALVE STAINLESS BASKET

PN 16 Rated CWP  
MOT 70 Deg C  
Also available in full Stainless Steel  
Smaller sizes screwed 15mm to 80mm in Brass or Stainless

FEATURES
CAST IRON BODY
SPRING LOADED JUMPER
CONICAL JUMPER ENSURES LOW HEAD LOSS
STAINLESS STEEL 304 BASKET
EXTERNAL AND INTERNAL EPOXY PAINTING
FLANGES ARE DRILLED TO CLIENT SPECIFICATIONS
NON-DRINKING WATER
ALL VALVES PRESSURE TESTED DURING PRODUCTION
SIZE RANGE: 80MM TO 200MM



MATERIALS		
POS.	PART NAME	MATERIALS
1	BODY	CAST IRON
2	GASKET	NBR
3	JUMPER	STAINLESS STEEL 316
4	SPRING	STAINLESS STEEL 302
5	JUMPER GUIDE	STAINLESS STEEL 316
6	BOLT	STAINLESS STEEL 304
7	NUT	STAINLESS STEEL 304
8	BASKET	STAINLESS STEEL 304

DIMENSIONS - mm						
Size	H	B	L	D	Kv	Wgt kg
80	200	148	257	5	258	10.73
100	220	168	317	5	360	15.00
150	286	222	426	5	628	30.80
200	340	278	546	5	985	51.80