

# Larox Valves

## PINCH VALVES

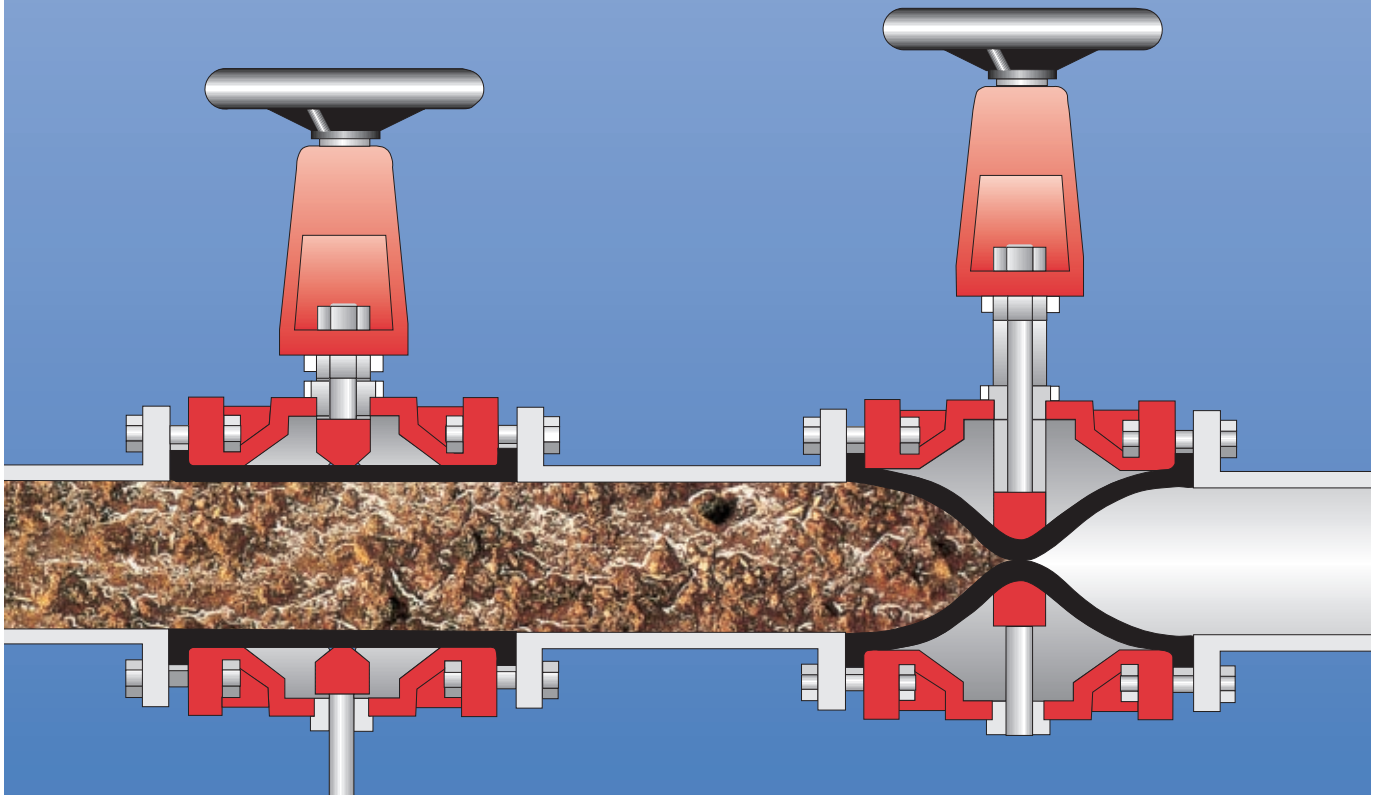

**Brisbane Sydney Melbourne Darwin**  
VALVE AND FLOW CONTROL SPECIALISTS PTY LTD  
E-mail [sales@valveandflowcontrolspecialists.com](mailto:sales@valveandflowcontrolspecialists.com)



# Simple guidelines – multiple advantages

**Whenever shut-off or control applications involve abrasive or corrosive slurries, powders, or granular substances, the Larox Valve is the optimum solution. The modern pinch valve technology offers substantial savings through superior performance, longer service lifetime and low maintenance costs.**

**The Larox Valve consists of three main components: sleeve, valve body, and actuator. The versatile construction of the Larox Valve enables a customer to choose any actuator, valve body construction or sleeve material according to their process conditions. The variety of combinations is almost unlimited.**

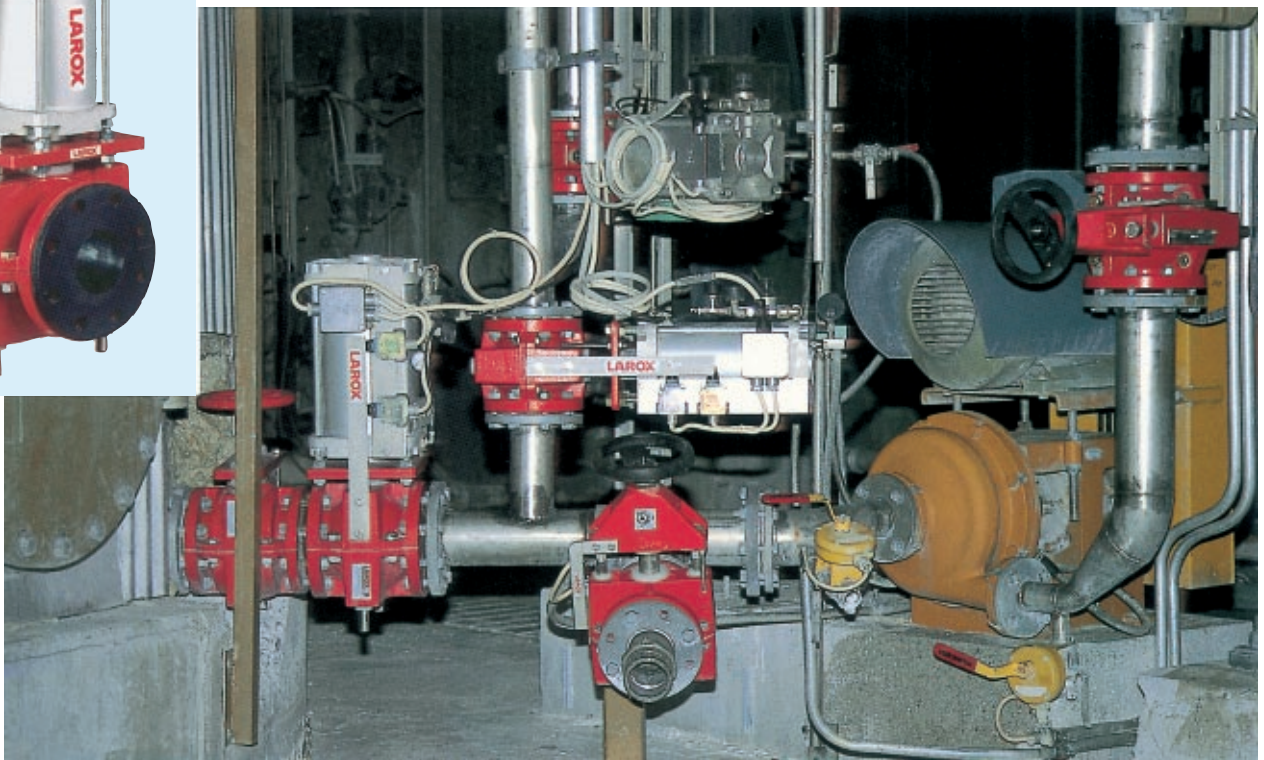

## High wear resistance

The valve sleeve is the only part in contact with the fluid flow. By selecting the right elastomer quality according to the flowing medium the highest resistance against abrasive and corrosive conditions can be achieved.

## Trouble-free operation

The valve sleeve is not affected by encrustation or hardening due to scaling liquors.

Any encrustation will separate itself from the elastic surface of the sleeve in the course of normal use, and will not prevent opening or closing of the valve.

## Low flow resistance

In the fully open position, the sleeve of a pinch valve becomes an integral part of the pipeline. The full-bore solution ensures an unobstructed flow essential for coarse slurries.

The unique design of Larox Valves also

ensures low flow resistance.

The advantageous flow properties reduce considerably power loss in the pipework, which means savings on the pumping costs.



# Larox Valve engineering service

**The standard range of Larox Valve solutions is for diameters 25 mm – 1000 mm, temperatures -50 °C – +160 °C, and pressures 0 – 100 bar. The applicability and performance of Larox Valves is dependent on these three basic elements and the process conditions. In co-operation with the customers Larox can engineer a solution to solve problems in applications outside the standard Larox product range.**

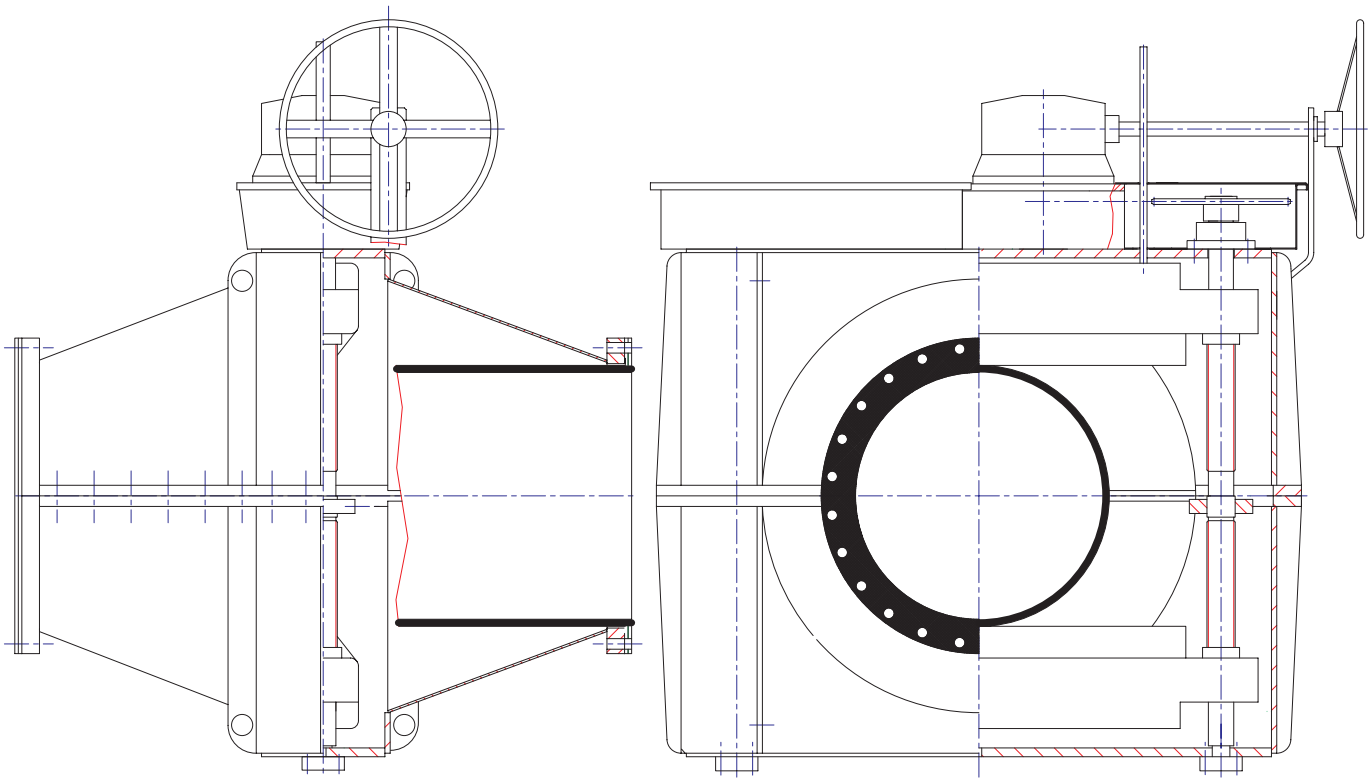

This enclosed body 700 mm Larox Valve has been designed according to specific customer requirements.

## Excellent control properties

The control curve of Larox pinch valves is nearly linear which corresponds to a wide and accurate control range.

## Low cost spare parts

The only wearing part of the Larox Valve is the elastic sleeve. It can be replaced using standard tools without special training or costly machining operations. Periodic

sleeve replacements guarantee reliable and undisturbed operation in critical applications.

## Modular structure

The Larox Valve has a modular structure, which gives our customers the possibility to choose any actuator, body, or sleeve type according to their needs.

## Remarkable investments in R & D

The Larox engineering service is continuously developing and testing new materials and equipment in co-operation with the customers to expand the operational range of Larox Valves.

# Larox Valve sleeve – the best sleeve available

**Larox pinch valves have been operated in highly abrasive or aggressive service for tens and hundreds of thousands of opening/closing cycles with no loss of the original tight shut-off capability and control capacity. The valve construction allows the valve to operate reliably after being in a closed or open position for prolonged periods with crystallising media; the opening and self cleaning properties of the Larox Valve remain unchanged.**



## Larox Valve sleeve – the heart of the Larox Valve

The valve sleeve is the only part in contact with the product flow. The selection of the sleeve material is very essential to guarantee the best wear resistance and longest lifetime for the valve sleeve and a trouble-free function of the process.

Larox Valve sleeves have a thick wear resistant inner lining, several textile reinforcing cord layers and a wear resistant outer surface. The process conditions such as pressure class, application, medium, and temperature determine the final selection of the valve sleeve material.

The standard Larox sleeve is supplied with positive opening tags. The opening

tags are particularly suited to applications with low pressures, high temperatures, and vacuum conditions as well as in situations where the valve has been closed for a longer period of time.

The Larox Valve sleeves are available in many grades of elastomers from wear resisting natural rubber to various rubber compounds developed to combat the arduous conditions in chemical processing.

### Early detection sleeve

Larox SensoMate is an early detection sleeve, which will signal locally or at the PLC when the sleeve is beginning to wear. The SensoMate sleeve has a steel mesh vulcanised between the wear layer and

the reinforcement cords of the sleeve. Deterioration of the inner wear layer of the sleeve allows the fluid to contact the wire mesh. This creates a change in conductivity between the pipeline and the wire mesh. The change in conductivity will be detected through SensoMate alarm and is indicated locally or communicated to the PLC.

Special sleeve designs are also available for control service, throttling, vacuum and high temperature applications.

Larox pinch valves and sleeves are manufactured in accordance with ISO 9001 quality specifications.

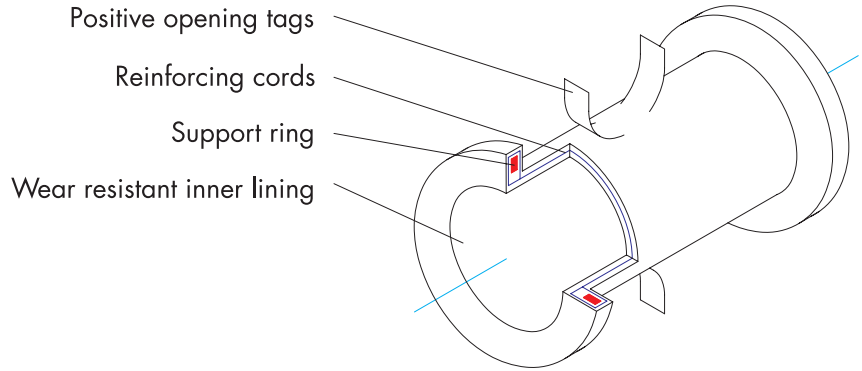

## STANDARD SLEEVE MATERIALS FOR LAROX VALVES

Rubber quality	Examples of the use of Larox Valves
<b>LAROX SBRT, STYRENE BUTADIENE</b> Larox standard sleeve material	Wearing applications High cycling applications Resistance against some chemicals Temperature range -40 to 110 °C
<b>EPDM, ETHYLENE PROPYLENE</b> Larox standard sleeve material	Good resistance against many chemicals Temperature range -40 to 120 °C

## ADDITIONAL SLEEVE MATERIALS

Rubber quality	Examples of the use of Larox Valves
<b>NR, NATURAL RUBBER</b>	Extremely wearing applications Temperature max. 75 °C NR/F, Foodstuff (white inner lining) quality available
<b>NBR, NITRILE RUBBER</b>	Good resistance to oils, animal and vegetable fat Temperature max. 100 °C NBR/F, Foodstuff (white inner lining) quality available
<b>HNBR, HYDROGENATED NITRILE</b>	Good wear resistance in high temperatures Temperature max. 160 °C
<b>CR, CHLOROPRENE RUBBER</b>	Resistance to ozone and weather Vegetable oils, aliphatic, naphthenic and nonaromatic oils Temperature max. 100 °C
<b>FPM, FLUORINE RUBBER</b>	Best resistance to chemicals Temperature max. 120 °C, less cycles in high temperatures
<b>CSM, HYPALON</b>	Very good resistance to acids and alkalis Good resistance to ozone, weather and chemicals Temperature max. 100 °C Low flammability Excellent resistance to great number of corrosive or oxidizing materials
<b>IIR, BUTYL</b>	Good impermeability to gases Very good resistance to acids and alkalis Good resistance to chemicals Temperature max. 100 °C
<b>PU, POLYURETHANE</b>	Applications with abrasive media

The process temperature may temporarily exceed the maximum sleeve temperature without any affects in the sleeve construction and operating properties.

**The final selection of the rubber material quality depends on the application, flowing medium and the mechanical stress.**



# Valve body types



**PV OPEN BODY**

The open body construction is designed for applications with relatively low pressures and low temperatures when the flowing medium is non-hazardous. The open body construction is light and it is very easy to access for service.

The available valve diameters begin with 80 mm. The standard body material is mild steel, but AISI316 bodies can also be delivered upon request.

The open body tolerates misalignment and vibration.



**PVE ENCLOSED BODY**

In the enclosed body construction, the valve sleeve is covered by the body housing, which protects the sleeve from the environment and sunlight. The available body materials are cast iron/mild steel, aluminium, plastic and AISI316.

**PVE/S**

A special model of the enclosed body construction PVE/S is designed for applications where fugitive emission protection is specified.

The valve body is equipped with a tap in the lower half of the body with a threaded AISI316 plug. Additionally, available is a gauge indicating the pressure changes in the valve body.



**PVS SEALED BODY**

The sealed body construction is designed for applications where no leakage of the flowing medium through the valve body is allowed to the environment. The PVS model has proved especially successful in high pressure applications due to the extremely resistant body construction. The sealed body can be equipped with an alarm or piping to ensure that the sleeve rupture can be noticed immediately.

The PVS structure has no rising parts outside the body.

The body materials can be chosen from cast iron/mild steel, aluminium or AISI316.

All the valve bodies are flange ended. The standard flange drillings are according to the DIN, ANSI, and BS/AS standards. Any special customer requirements can be accomplished upon request.

The Larox Valves close on center line to maximise the sleeve life time and provide better control in modulating or throttling applications.

# Actuators for every need

## MANUAL ACTUATORS (M)

The manual valves are equipped with a handwheel actuator. The screw mechanism of the manually operated valves is totally enclosed, and thus protected against dirt and corrosion to ensure reliable operation.

The large diameter manual valves and the valves used in high-pressure applications come equipped with a reduction gear to ease the operation. Manual valves can also be fitted with a chain wheel and extended stem.



PVE 80 M6-233



PVE 200 M16-303

## AUXILIARIES FOR THE MANUAL VALVES

- L** = Opening tags for assisted opening
- R** = Inductive proximity sensors:
  - Telemecanique XS1-N18 (DC 3W PNP or NPN)
  - Telemecanique XS1-M18 (AC/DC 2W)
  - Other brands upon request
- T** = Mechanical limits:
  - Telemecanique XCK-M102
  - Other brands upon request
- X** = Special auxiliaries available upon request.



Manual valves are generally used in the pulp & paper recausticizing applications.

# Actuators for every need

## PNEUMATIC ACTUATORS (A)

The pneumatic actuator is a double acting cylinder. The standard supply pressure for the pneumatic cylinder is min. 6 bar. The cylinder size is determined according to the process line pressure.

The pneumatic actuator is also available in special materials for aggressive conditions.

PVE 100 A6-203



PVS 80 A1-233

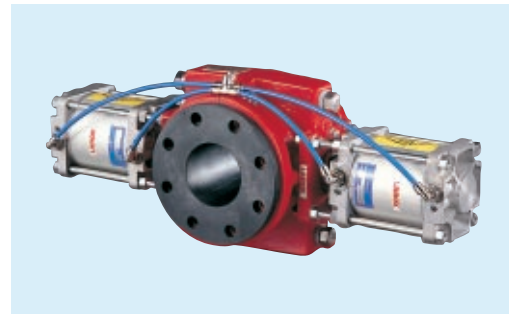

Sealed valve is always operated with dual pneumatic actuators.

## WIDE VARIETY OF PNEUMATIC ACTUATORS

### Pneumatic actuator with manual override (AB)

The valve can be equipped with a manual override to ensure that in malfunction situations such as a loss of air supply the valve can be closed with the handwheel.



PVE 50 AB1-201 Z

### Pneumatic actuator with pneumatic spring (AU)

The pneumatic spring ensures that the valve can be opened or closed if the supply pressure is suddenly not available. The valve can be opened or closed only once in the malfunction situation and the function is dependable for 1 - 2 days.

The pneumatic spring can be operated through a separate or an integrated air tank.



PVE 100 AU1-201

### Pneumatic actuator with mechanical spring (AV)

Single acting pneumatic actuator provided with a mechanical spring to close or open the valve.



PVE 50 AV10-201



## CONTROL VALVE ACTUATORS

### Pneumatic actuator with pneumatic positioner (AN)

The standard pneumatic positioners in the Larox Valves are Posiflex positioners. The standard incoming signal is 0.2 - 1 bar and the increasing signal closes the valve.

### Pneumatic actuator with electro-pneumatic positioner (AK)

The standard electro-pneumatic positioners are Posiflex positioners. The standard incoming signal is 4-20 mA and the increasing signal closes the valve.



PVE 100 AK10-203

## AUXILIARIES FOR PNEUMATIC ACTUATORS

- L** = Opening tags for assisted opening
- Q** = Quick exhaust valves for pneumatic actuator
- R** = Inductive proximity sensors:
  - Telemecanique XS1-N18 (DC 3W PNP or NPN)
  - XS1-M18 (AC/DC 2W)
  - Neles NI 7211 (NAMUR)
  - Other brands upon request
- S** = Magnetic limits attached to the actuator with a magnetic ring in the piston.
- T** = Mechanical limits:
  - Telemecanique XCK-M102
  - Neles NK 7201
  - Other brands upon request
- Z** = Solenoid valve (5 way 5/2) for pneumatic actuator; Camozzi 454-015-220V-50/60Hz or - 24V-DC, others on request
- Lucifer 341 PO2**
- X** = Special auxiliaries available upon request

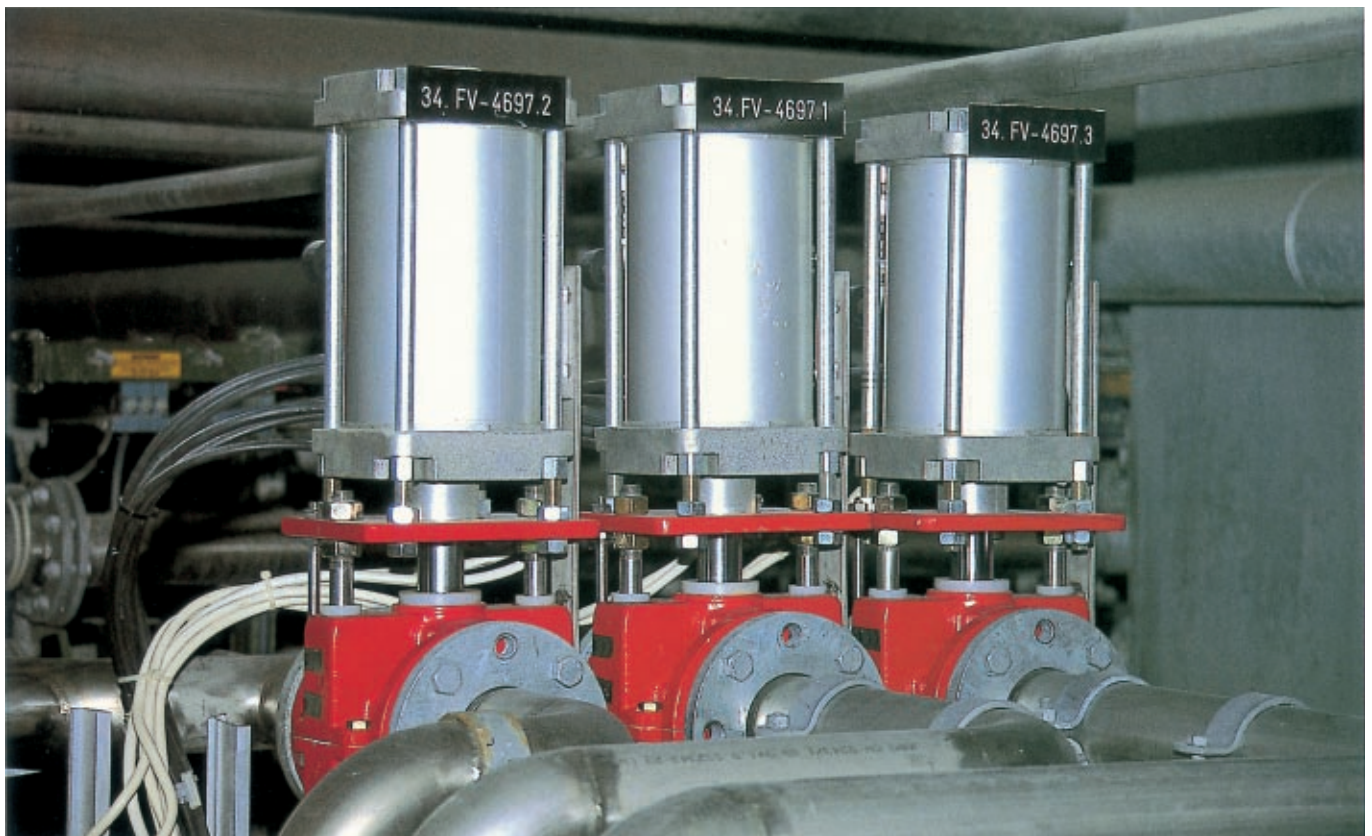

Pneumatic Larox Valves provide an excellent solution for abrasive conditions such as calcium carbonate handling.



# Actuators for every need

## HYDRAULIC ACTUATORS (H)

The hydraulic actuator is a double acting cylinder. The standard supply pressure for the hydraulic cylinder is min. 150 bar. The final cylinder size is determined according to the line pressure.

The standard cylinder is equipped with a pilot operated check valve, which keeps the valve in position when hydraulic pressure is not available.

### Hydraulic actuator with electro-hydraulic positioner (HP)

For demanding flow control the hydraulic actuator can be delivered with an electro-hydraulic positioner. The standard incoming signal for the electro-hydraulic positioner is 4-20 mA.

The Larox Valve product range includes also hydraulic power packs to actuate the hydraulic valves. Tailor made solutions are available upon customer requests.



PVE 100 H16-233 R



Larox Valves have been approved as the standard solution for over 600 Larox pressure filters.

### AUXILIARIES FOR HYDRAULIC ACTUATORS

- L** = Opening tags for assisted opening
- R** = Inductive proximity sensors
  - Telemecanique XS1-N18 (DC 3W PNP or NPN)
  - XS1-M18 (AC/DC 2W)
  - Neles NI 7211 (NAMUR)
  - Other brands upon request
- T** = Mechanical limits:
  - Telemecanique XCK-M102
  - Neles NK 7201
  - Others on request
- X** = Special auxiliaries available upon request



**ELECTROMECHANICAL ACTUATORS (E)**

The standard electromechanical actuator types are AUMA Norm SA-series and Rotork IQ-series actuators equipped with build-in limit switches and manual hand-wheel. The standard voltage is 400V 50Hz, others on request.

**Electromechanical actuator with electronic positioner (EO)**

The standard actuators are AUMA Norm SA-series with RWG, AUMA Matic SAM series or Rotork IQ-series. The standard incoming signal for the electromechanical positioner is 4-20 mA. All electromechanical actuators are supplied complete with manual override.

**AUXILIARIES FOR ELECTROMECHANICAL ACTUATORS**

- L = Opening tags for assisted opening
- X = Special auxiliaries available upon request



PVE 100 E6-201 (Auma Norm)



PVE 100 EO6-201 (Auma Matic)



PVE 100 E6-201 (Rotork IQ)



The electromechanically actuated valves are widely used in the oil & offshore industry.



# Valve type markings

**Example order code: PVE100AK10 - 203L**

The example order code refers to the following Larox Valve:

Enclosed body, valve size 100 mm, pneumatic actuator with electropneumatic positioner, pressure 10 bar with DIN PN10 flange drillings, body material Fe, flange shape 3 and opening tags.

PVE	100	AK	10	= 2	0	3	L
MODEL	SIZE (DN)	ACTUATOR	PRESSURE CLASSES (PN)	FLANGE DRILLINGS	BODY MATERIAL	SHAPE OF FLANGE	AUXILIARIES
PV = open PVE = enclosed PVS = sealed PVE/S = enclosed/sealed	25-1000	M = handwheel A = pneumatic AB = with manual override AK = with el.pneum. positioner AN = with pneum. positioner AU = with pneum. spring AV = with mech. spring H = hydraulic HP = with hydraulic positioner E = electro mechanical EO = with electr. positioner	1 = 1 bar 6 = 6 bar 10 = 10 bar 16 = 16 bar 25 = 25 bar 40 = 40 bar 64 = 64 bar 100 = 100 bar	1 = - 2 = DIN PN 10 3 = DIN PN 16 4 = DIN PN 25 5 = DIN PN 40 6 = ANSI 150* 7 = ANSI 300* 8 = B.S. TABLE D 9 = other	0 = Fe 1 = - 2 = AISI 316 3 = AISi 4 = other 5 = PU	Determined by the valve manufacturer  type 1 type 2 type 3 type 4	L = opening tags Q = quick exhaust valve R = inductive limits S = magnetic limits T = mechan. limits Z = solenoid valve X = other, must be specified

- \*) Fe DN25-200: GRS 250 (DIN 1691-GG25), epoxy painted K18-E180/2-FeSa 2Ω  
DN200...: Fe37B (DIN 17100-Rst-2), epoxy painted K180-E180/2-FeSa 2Ω  
AISI 316 DN25-200: casted (DIN 17445; 1.4408)  
DN250...: welded (DIN 17122-17440)  
AISI DN25-150: aluminium alloy (DIN 1725 AISi 12) epoxy painted K18-E180/2-FeSa 2Ω  
PU Ciba 5000 series

# Sleeve type markings

NR	10	300	/ 750	/ 3	L	2
SLEEVE MATERIAL	PRESSURE CLASSES (PN)	SLEEVE INNER DIA (mm)	SLEEVE LENGTH (mm)	SHAPE OF FLANGE	TAGS	FLANGE DRILLINGS
NR = natural rubber NRF = natural rubber foodstuff quality SBRT = styrene butadiene IIR = butyl NBR = nitrile HNBR = hydrogenated nitrile NBRF = nitrile foodstuff quality FPM = fluorine rubber CSM = chloro-sulphone-ethene EPDM = ethylene propylene PU = polyurethane CR = chloroprene ___/PU = PU-coating inside the sleeve ___/M = Larox SensoMate sleeve	1 = 1 bar 6 = 6 bar 10 = 10 bar 16 = 16 bar 25 = 25 bar 40 = 40 bar 64 = 64 bar 100 = 100 bar			type 1 type 2 type 3 type 4	- = none L = yes	1 = - 2 = DIN PN 10 3 = DIN PN 16 4 = DIN PN 25 5 = DIN PN 40 6 = ANSI 150* 7 = ANSI 300* 8 = B.S. TABLE D 9 = other

In spare sleeve orders, please use 4- or 5- figure code marked on the sleeve.

\* drilled and tapped to suit to ANSI B 16.5 flanges.

**Brisbane Sydney Melbourne Darwin**  
VALVE AND FLOW CONTROL SPECIALISTS PTY LTD  
E-mail sales@valveandflowcontrolspecialists.com