

ECCENTRIC PLUG VALVE, EN-STD, PN16 (Rectangular Port) **AVK 65-300** | **764/01-001**
Flanged, bare shaft, wastewater, NBR rubber, A4 bolts, DN 65-300

The eccentric plug valves are quarter turn with obstacle-free bore, adapted for pump control shut-off and throttling service with bi-directional flow in applications where waste water is contaminated with particles or hydrocarbon residues. The plug is fully vulcanized with AVKs own hydrocarbon resistant NBR rubber compound which due to its sturdy design, double bonding vulcanization and the rubber's ability to regain its original shape features an outstanding durability. The valve seat is corrosion resistant, welded nickel with a full port design that allows for high flow capability, an ISO 5211 actuator flange is incorporated in the valve housing and fusion bonded epoxy coating protects internally and externally.

Product description:

Resilient seated, quarter turn, eccentric plug valve with welded nickel seat, for wastewater to max. 70°C

Standards:

- Designed according to AWWA C517
- Face to face according to EN 558 Table 2 Basic Series 3
- Standard flange drilling to EN1092-2 (ISO 7005-2), PN 16

Test/Approvals:

- Hydraulic tests according to DIN EN 1074-1 and 5, cover:1.1×PN, body:1.5×PN

Features:

- Quarter turn with no shaft through the bore gives a quickly operated valve that is not clogged by stringy or fibrous objects in the water
- Seat in 95% nickel, welded on the cast body for corrosion protection and extended life time
- Round rubber bonnet gasket that fits into a groove in the valve bonnet preventing it from being blown out by pressure surges
- Bonnet gasket and plug rubber in hydrocarbon resistant NBR according to EN681-1
- Bonnet bolts in stainless steel A4-70, encircled by the bonnet gasket and sealed with hot melt
- Fusion bonded epoxy coating to DIN 30677-2, GSK approved, blue RAL5017
- V-type stem seal packing, easily adjustable during use
- Self-lubricating, stainless steel backed, PTFE coated, bronze bearing along with upper and lower bronze washers ensures consistently low operating torque
- Actuator mounting flange to ISO 5211
- Rectangular port opening, full port area
- Flange feet on large sizes for easy transport
- Seals from both directions up to 16 bar
- Plugs with integrated stems
- Plug stem extensions with zinc plating for corrosion protection
- Main stem seal and bearings are protected from particles and grit in the liquid by a triple lip integrated in the plug rubber coat pressing against the inside of the thrust bearing. Parallel to that an O-ring also seals the outside of the thrust bearing and the inside of the radial bearing

Accessories:

Gearbox, electric actuator



ECCENTRIC PLUG VALVE, EN-STD, PN16

764/01-001

Flanged, bare shaft, wastewater, NBR rubber, A4 bolts, DN 65-300

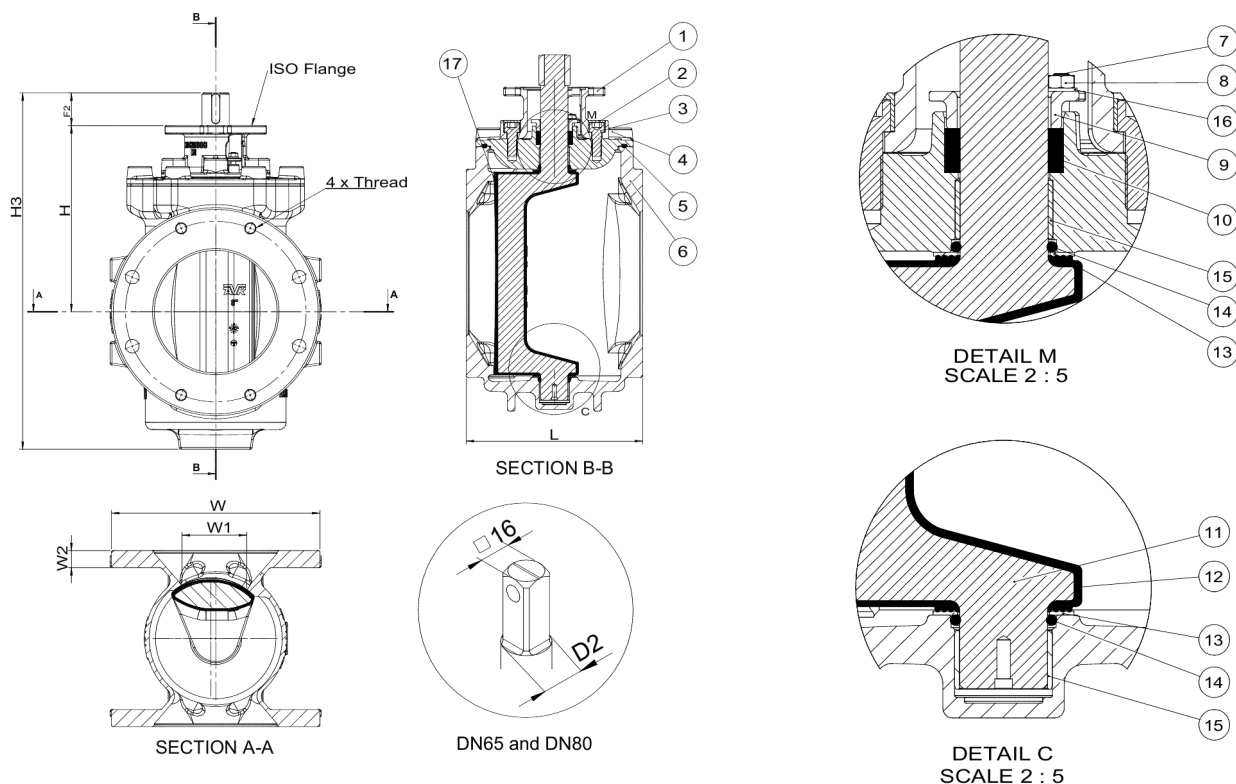

Component list:

1. ISO flange	Ductile iron GJS-450-10	10. V-pack	NBR rubber
2. Sealing	Hot melt glue	11. Plug core	Ductile iron GJS-450-10
3. Bolt	Stainless steel A4-70	12. Plug rubber	NBR rubber
4. Bonnet	Ductile iron GJS-450-10	13. Thrust washer	Bronze CC499K
5. Bonnet gasket	NBR rubber	14. O-ring	NBR rubber
6. Body	Ductile iron GJS-450-10	15. Bearing	Bronze / PTFE composite
7. Stud	Stainless steel A4-70	16. Washer	Stainless steel A4-70
8. Hex nut	Stainless steel A4-70	17. Seat	Nickel
9. Gland	Ductile iron GJS-450-10		

Components may be substituted with equivalent or higher class materials without prior notification.

Reference nos. and dimensions:

	DN	L	W	W1	W2	H	H3	F2	D2	ISO Flange	Thread	Key	No. of keys	Theoretical weight / kg
764-065-01-1306400000	65	190	180	37	17.5	172	303	34	22	F07	-	-	-	15
764-080-01-1306400000	80	203	200	57	19	170	304	34	25	F07	M16	-	-	21
764-100-01-1306400000	100	229	230	69	24	190	347	39	28	F10	M16	8X7X32	2	29
764-150-01-1306400000	150	267	285	96	25	224	418	40	35	F10/12	M20	10X8X32	2	45
764-200-01-1306400000	200	292	345	107	29	309	591	54	45	F14	M20	14X9X50	2	76
764-250-01-1306400000	250	330	405	135	30	367	704	59	55	F14/16	M24	16X10X56	2	115
764-300-01-1306400000	300	356	485	152	32	419	821	65	60	F14/16	M24	18X11X63	2	167

The designs, materials and specifications shown are subject to change without notice due to the continuous development of our product range.