

Aeration and vent valve BE 891

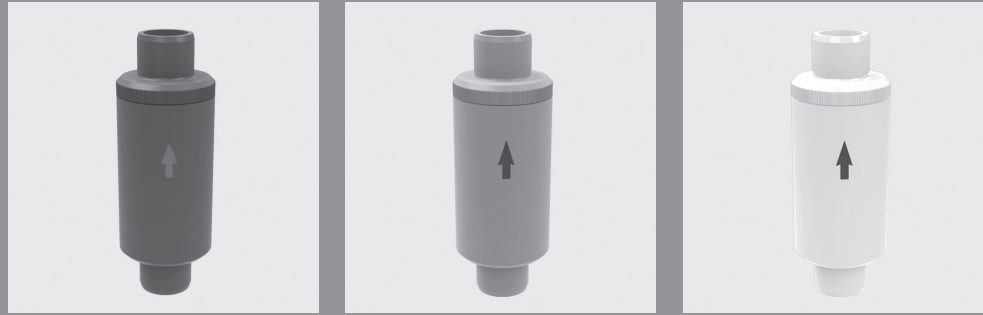

Advantage

- high level of operating safety and long service life
- low-maintenance
- can be easily connected to the pipework by proven technologies
 - solvent or fusion welding

Application

- chemical plants
- water treatment

Utilisation

- for aerating and venting technical processing plants

Function

- When fluid is removed from the container, the valve ball/float is located at the bottom of the valve. Air or protective gas can flow into the container, providing pressure compensation to ensure that the container is not damaged by a vacuum.
- When the container is filled, the air/protective gas escapes through the valve into the atmosphere until the fluid level reaches the valve ball/float. When the container is filled further, the valve ball/float rises with the fluid level and seals the container at the valve seat.

Attention

- Due to the function only vertical mounting is possible!
- When the valve is closed, venting is only possible when the container pressure falls below the atmospheric pressure even with air build-up (outgassing media).
- The valves are not suitable for fluids that clog or gum up the balls/floats, impairing their opening and closing action.

Flow Media

- Technically pure, neutral or aggressive fluid or gaseous media, provided that the valve components coming into contact with the media are resistant at the operating temperature according to the ASV resistance guide!

Nominal Pressure (H₂O, 20°C)

- PN 10

Fluid Temperature

- see pressure/temperature diagram

Operating Pressure

- see pressure/temperature diagram

Size

- DN 10 - DN 50

Body

- PVC-U
- PP
- PVDF

Ball

- PP

Pressure Ring

- PVC-U
- PP
- PVDF

Sealing

- FPM

Actuation

- medium controlled

Connection

- spigot end for solvent welding DIN ISO (PVC-U)
- fusion spigot end DIN ISO (PP)
- fusion spigot end DIN ISO (PVDF)

Mounting

- vertical mounting only
- observe marking »TOP«!

Aeration and vent valves, Aeration and vent valve BE 891

Pressure/temperature diagram

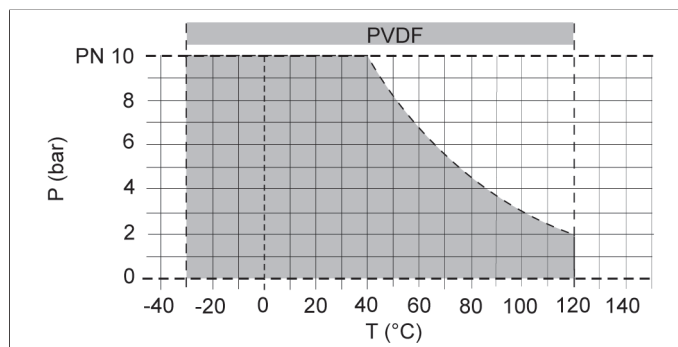
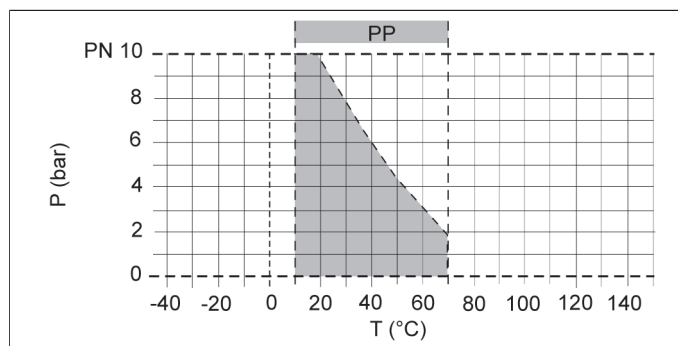
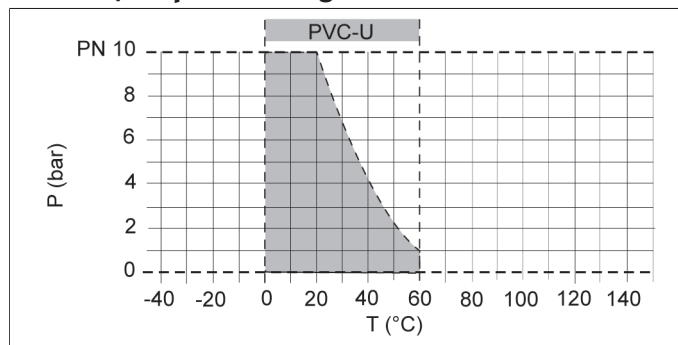

P = operating pressure

T = temperature

The pressure/temperature limits are applicable for the stated nominal pressures and a computed operating life factor of 25 years. These are standard values for harmless media (DIN 2403), to which the valve material is resistant.

For other media please refer to the ASV resistance guide.

The durability of wear parts depends on the operating conditions of the application.

For temperatures below 0°C (PP < +10°C) please specify the precise operating conditions of the application.

The rated pressure depends on the valve size and material. For the corresponding rated pressure value of the valve, please refer to the »Order table«.

BE 891 Flow Q

d (mm)	16	20	25	32	40	50	63
Q (Nm ³ /h)	10	14	18	40	60	75	85

Standard values: flow velocity $V_{air} \sim 10-20$ m/s

Flow based on air (Nm³/h)

Operating note

Safe operation of the valve can only be ensured if it is properly installed, operated, serviced or repaired by qualified personnel according to its intended use while observing the accident prevention regulations, safety regulations, relevant standards, directives/technical regulations or codes of practice such as e.g. DIN, DIN EN, DIN ISO and DVS*. *DVS = German Welding Society

The intended use includes adhering to specified limit values for pressure and temperature, as well as checking the resistance. This requires all components coming into contact with the medium to be "resistant" in accordance with the ASV resistance guide.

The use of the valves in tank installations must be checked by the customer with regard to the safety requirements.

Please connect an evacuation line with the aeration/vent valve. In the case of omission there is highest risk of injury due to escaping media.

Aeration and vent valves, Aeration and vent valve BE 891



body PVC-U

<i>size</i>	d(mm)	16	20	25	32	40	50	63	
	<i>pressure range</i>	DN(mm)	10	15	20	25	32	40	50
		DN(inch)	3/8	1/2	3/4	1	1 1/4	1 1/2	2
		PN(bar)	10	10	10	10	10	10	10
<i>Connection</i>	<i>sealing</i>	<i>ident No.</i>							
	PVC-U spigot end DIN ISO	FPM <i>weight</i>	54393 0.10 kg	54395 0.13 kg	54396 0.19 kg	54397 0.28 kg	54398 0.50 kg	54399 0.70 kg	54400 1.23 kg

body PP

<i>size</i>	d(mm)	16	20	25	32	40	50	63	
	<i>pressure range</i>	DN(mm)	10	15	20	25	32	40	50
		DN(inch)	3/8	1/2	3/4	1	1 1/4	1 1/2	2
		PN(bar)	10	10	10	10	10	10	10
<i>Connection</i>	<i>sealing</i>	<i>ident No.</i>							
	PP spigot end DIN ISO	FPM <i>weight</i>	55959 0.10 kg	54402 0.13 kg	55618 0.19 kg	54403 0.28 kg	60935 0.50 kg	56403 0.70 kg	65540 1.23 kg

body PVDF

<i>size</i>	d(mm)	16	20	25	32	40	50	63	
	<i>pressure range</i>	DN(mm)	10	15	20	25	32	40	50
		DN(inch)	3/8	1/2	3/4	1	1 1/4	1 1/2	2
		PN(bar)	10	10	10	10	10	10	10
<i>Connection</i>	<i>sealing</i>	<i>ident No.</i>							
	PVDF spigot end DIN ISO	FPM <i>weight</i>	64153 0.10 kg	67755 0.13 kg	60664 0.19 kg	60626 0.28 kg	67756 0.50 kg	64072 0.70 kg	64106 1.23 kg

Aeration and vent valves, Aeration and vent valve BE 891

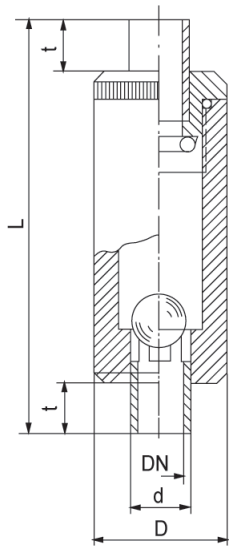

dimensions

d(mm)	16	20	25	32	40	50	63
DN(mm)	10	15	20	25	32	40	50
DN(inch)	3/8	1/2	3/4	1	1 1/4	1 1/2	2
dimensions(mm)							
D	35	40	45	55	70	80	95
L	114	124	144	154	174	194	224
t	14	16	19	22	26	31	38

Aeration and vent valves, Aeration and vent valve BE 891

parts lists

d16 -d63

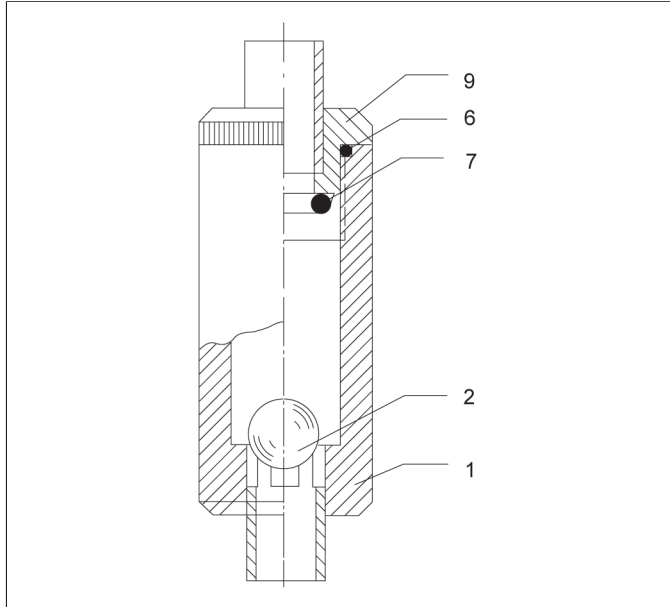

position	quantity	designation
1	1	housing/body
2	1	ball
6	2	O-ring
7	1	O-ring
9	1	bonnet