



V83 Series Swing-Out Ball Valves

No.V83-8

Pressure Rating up to 3,000 psig (206 bar)



Features

- Pressure and temperature compensation seat design.
- Swing-out design for fast and easy maintenance with the valve in-line.
- Chevron packing design.
- 2-way (on-off) valves with quarter-turn actuation.

Two flats on stem (10) and lever handle (13) indicate open or closed position of the valve.

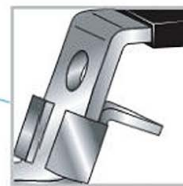
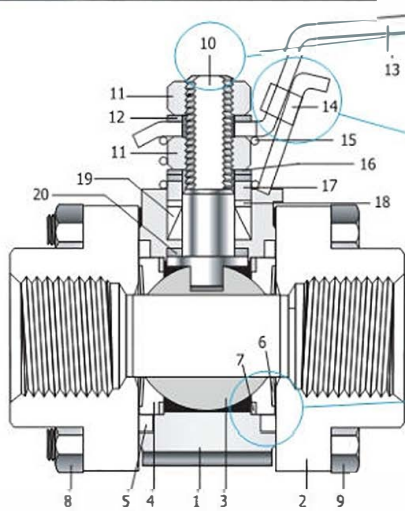

Built-in manual locking device (14) allows locking the valve with a detent either in open or closed position. You may also apply a pad-lock to this device. Pad-lock hole: 8 mm (0.314 in.)

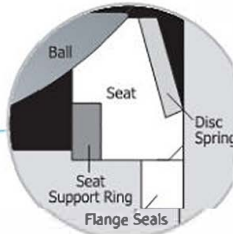

Compensation seat design requires no pressure to create a seal. Under high pressure, seats react on the ball movement for sealing at upstream and downstream.

Table 1. Material of Construction

Component	Valve Body Materials	
	Stainless steel	Carbon Steel
	Grade / ASTM Specification	
1. Body	CF3M / A351	WCB / A216
2. Flanges (2)	CF3M / A351	WCB / A216
3. Ball	Type 316 / A276	
4. Seats (2)	See Table 2.	
5. Flange Seals (2)	PTFE	
6. Disc Spring (2)	Strain Hardened SS316	
7. Seat support rings (2)	Type 316 / A276	
8. Body fasteners (4)	SS316 Gr.8M/ A193	
9. Bodyhex nuts(4)	SS316 Gr.8M/ A194	
10. Stem	Type 316 / A276, A479	
11. Stem Nuts (2)	SS316	
12. Tooth Washer	Stainless steel	
13. Handle	SS304 with Vinyl sleeve	
14. Locking Device	SS304	
15. Grounding spring	SS312 / A313	
16. Stem Springs (2)	Strain Hardened SS316 / A240	
17. Gland	Type 316 / A276	
18. Packing Support	PEEK (Polyetheretherketone)	
19. Upper & Lower Packing	Reinforced PTFE	
20. Stem Bearing	PEEK, Optional X750	

• Wetted parts and lubricants are listed in blue.

Table 2. Seat Materials

Pressure - Temperature Ratings

Seats	Valve Series	Pressure Rating @ -28 to 38 °C (-20 to 100 °F)	Pressure @ Max. Temperature	Lubricants	
Standard Reinforced PTFE	V83A	151 bar (2200 psig)	7 bar @ 232°C 100 psig @450°F	Silicon based and PTFE based	
	V83B				
	V83C				
Virgin PTFE	V83A	103 bar (1500 psig)	7 bar @ 232°C 100 psig @450°F		
	V83B				
	V83C				
Carbon PTFE	V83A	172 bar (2500 psig)	7 bar @ 232°C 100 psig @450°F		
	V83B				
	V83C				
PEEK	V83A	206 bar (3000 psig)	55 bar @ 232°C 800 psig @ 450°F		PTFE based
	V83B				
	V83C				
UHMWPE	V83A	206 bar (3000 psig)	17 bar @ 121°C 250 psig @ 250°F	Hydrocarbon based and PTFE based	
	V83B				
	V83C				

Factory Test

Every valve is tested with nitrogen @ 68.9 bar (1,000 psig) for leakage at the seat to a maximum allowable leak rate of 0.1 SCCM. Shell test with nitrogen @ 68.9 bar (1,000 psig) is performed to a requirement of no detectable leakage with a liquid leak detector. Shell test with water at 1.5 times the working pressure is performed on request with extra cost.





PRESSURE-TEMPERATURE GRAPH

Reinforced PTFE

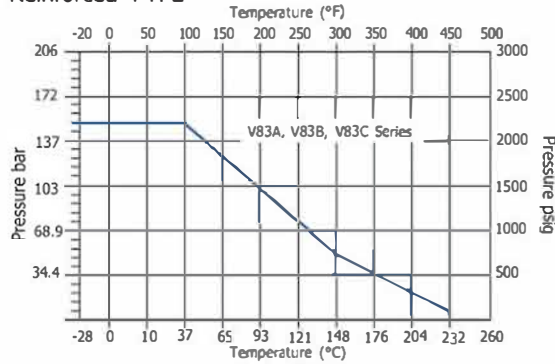

PTFE

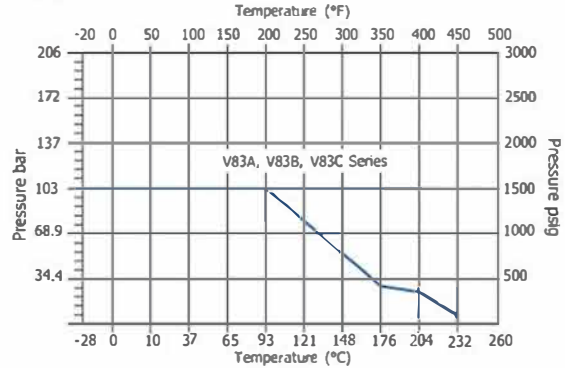

Carbon PTFE

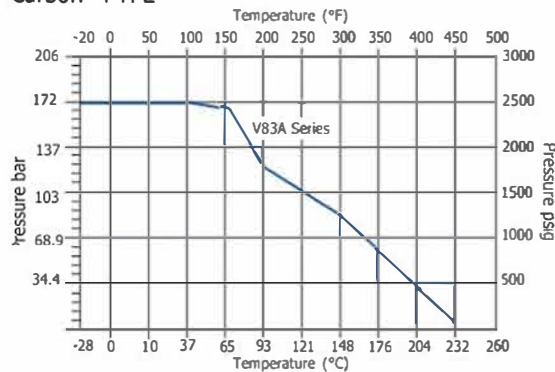

Carbon PTFE

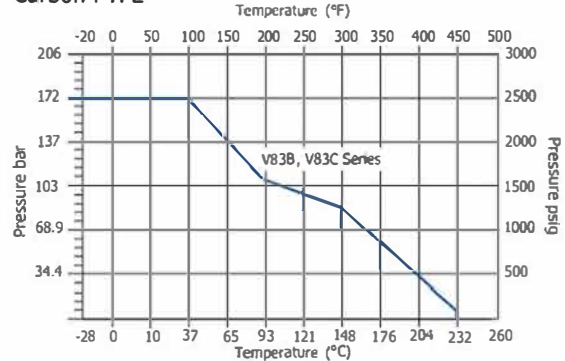

PEEK

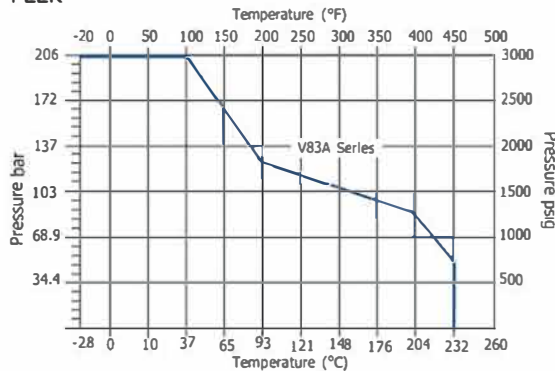

PEEK

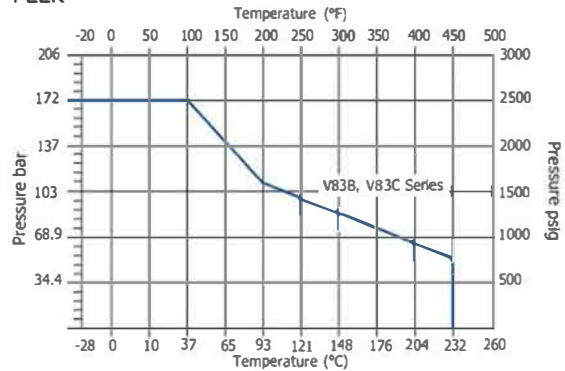

UHMWPE

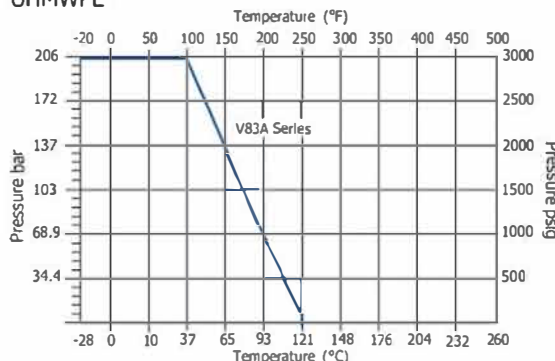

UHMWPE

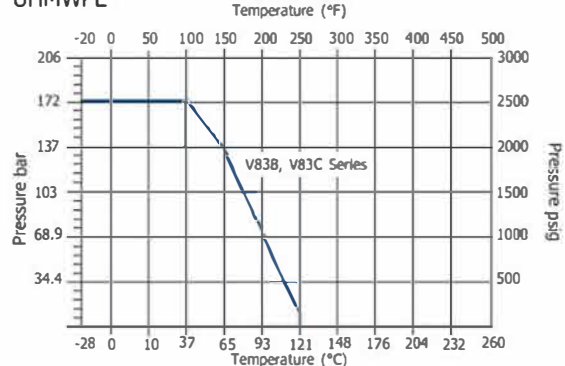

DK-Lok Tube Fitting End Connections

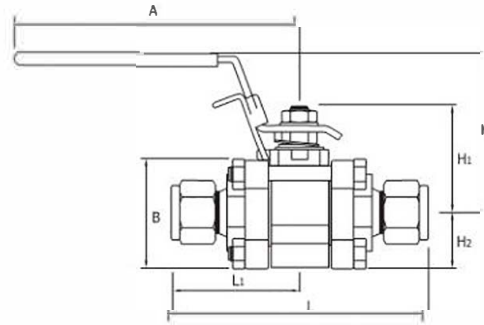

Basic Ordering number	End Connection	Orifice		Cv	Dimension mm (in.)						
		mm	in.		L	L1	H	H1	H2	A	B
Fractional DK-Lok											
V83A-D4T-	1/4 in.	4.8	0.188	1.2	80.8 (3.18)	40.40 (1.59)	47.7 (1.88)	31.8 (1.25)	16.75 (0.66)	57.2 (2.25)	33.0 (1.30)
V83A-D6T-	3/8 in.	7.1	0.281	3.8							
V83B-D8T-	1/2 in.	10.4	0.411	7.5	103.8 (4.09)	51.90 (2.04)	64.8 (2.55)	44.2 (1.74)	22.25 (0.88)	111.0 (4.37)	44.5 (1.75)
V83B-D12T-	3/4 in.	13.1	0.516	13.6							
V83C-D16T-	1 in.	22.2	0.875	40.0	136.7 (5.38)	68.35 (2.69)	79.0 (3.11)	61.9 (2.44)	31.00 (1.22)	149.4 (5.88)	62.0 (2.44)
Metric DK-Lok											
V83A-D6M-	6 mm	4.8	0.188	1.2	80.8 (3.18)	40.40 (1.59)	47.7 (1.88)	31.8 (1.25)	16.75 (0.66)	57.2 (2.25)	33.0 (1.30)
V83A-D8M-	8 mm	6.4	0.250	2.5							
V83A-D10M-	10 mm	7.1	0.281	3.8	103.8 (4.09)	51.90 (2.04)	64.8 (2.55)	44.2 (1.74)	22.25 (0.88)	111.0 (4.37)	44.5 (1.75)
V83B-D12M-	12 mm	10.4	0.411	7.5							
V83C-D25M-	25 mm	22.2	0.875	40.0	136.7 (5.38)	68.35 (2.69)	79.0 (3.11)	61.9 (2.44)	31.00 (1.22)	149.4 (5.88)	62.0 (2.44)

Female Pipe Thread End Connections

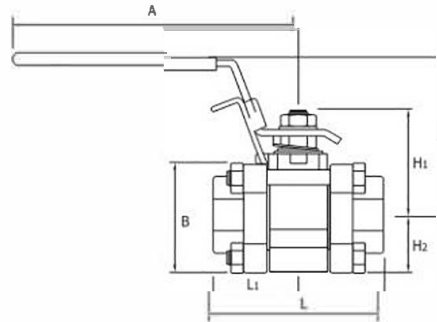
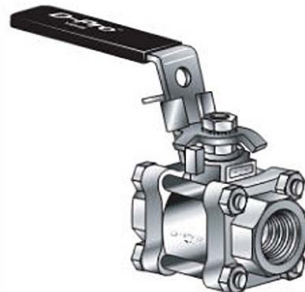

Basic Ordering number	End Connection	Orifice		Cv	Dimension mm (in.)						
		mm	in.		L	L1	H	H1	H2	A	B
Female NPT Ends											
V83A-F2N-	1/8 in.	7.1	0.281	3.8	55.4 (2.18)	27.70 (1.09)	47.7 (1.88)	31.8 (1.25)	16.75 (0.66)	57.2 (2.25)	33.0 (1.30)
V83A-F4N-	1/4 in.										
V83B-F6N-	3/8 in.	13.1	0.516	12.0	68.9 (2.71)	34.45 (1.36)	64.8 (2.55)	44.2 (1.74)	22.25 (0.88)	111.0 (4.37)	44.5 (1.75)
V83B-F8N-	1/2 in.										
V83C-F12N-	3/4 in.	22.2	0.875	31.0	92.0 (3.62)	46.00 (1.81)	79.0 (3.11)	61.9 (2.44)	31.00 (1.22)	149.4 (5.88)	62.0 (2.44)
V83C-F16N-	1 in.			38.0							
Female ISO Tapered Ends											
V83A-F4R-	1/4 in.	7.1	0.281	3.8	55.4 (2.18)	27.70 (1.09)	47.7 (1.88)	31.8 (1.25)	16.75 (0.66)	57.2 (2.25)	33.0 (1.30)
V83B-F8R-	1/2 in.	13.1	0.516	12.0	68.9 (2.71)	34.45 (1.36)	64.8 (2.55)	44.2 (1.74)	22.25 (0.88)	111.0 (4.37)	44.5 (1.75)
V83C-F12R-	3/4 in.	22.2	0.875	31.0	92.0 (3.62)	46.00 (1.81)	79.0 (3.11)	61.9 (2.44)	31.00 (1.22)	149.4 (5.88)	62.0 (2.44)
V83C-F16R-	1 in.			38.0							

Tube and Pipe Socket Weld End Connections

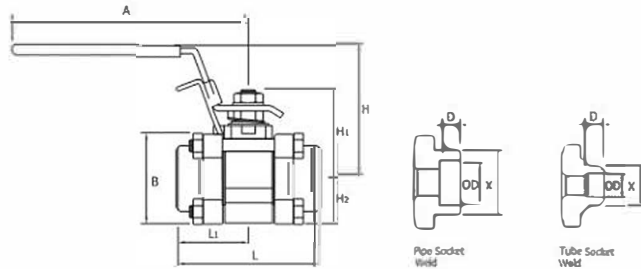

Basic Ordering number	End Connection	Orifice		Cv	Dimension mm (in.)									
		mm	in.		OD	X	D	L	L1	H	H1	H2	A	B
Tube Socket Weld														
V83A-SW4T-	1/4 in.	4.8	0.188	1.2	650 (0.26)	13.70 (0.54)	7.1 (0.28)	55.4 (2.18)	27.70 (1.09)	47.7 (1.88)	31.8 (1.25)	16.75 (0.66)	57.2 (2.25)	33.0 (1.30)
V83ASW6T-	3/8 in.	7.1	0.281	3.8	970 (0.38)	17.10 (0.67)	7.9 (0.31)							
V83B-SW8T-	1/2 in.	10.4	0.411	7.5	12.90 (0.51)	21.30 (0.84)	9.7 (0.38)	68.9 (2.71)	34.45 (1.36)	64.8 (2.55)	44.2 (1.74)	22.25 (0.88)	111.0 (4.37)	44.5 (1.75)
V83B-SW12T-	3/4 in.	13.1	0.516	13.6	19.20 (0.76)	26.70 (1.05)	11.2 (0.44)							
V83C-SW16T-	1 in.	22.2	0.875	40.0	25.65 (1.01)	33.40 (1.31)	16.0 (0.63)	92.0 (3.62)	46.00 (1.81)	79.0 (3.11)	61.9 (2.44)	31.00 (1.22)	149.4 (5.88)	62.0 (2.44)
Pipe Socket Weld														
V83B-SW8P-	1/2 in.	13.1	0.516	15.0	21.80 (0.86)	31.20 (1.23)	9.7 (0.38)	68.9 (2.71)	34.45 (1.36)	64.8 (2.55)	44.2 (1.74)	22.25 (0.88)	111.0 (4.37)	44.5 (1.75)
V83C-SW12P-	3/4 in.	22.2	0.875	36.0	27.20 (1.07)	42.16 (1.66)	12.7 (0.50)							
V83C-SW16P-	1 in.			42.0	33.90 (1.33)	45.30 (1.78)	92.0 (3.62)	46.00 (1.81)	79.0 (3.11)	61.9 (2.44)	31.00 (1.22)	149.4 (5.88)	62.0 (2.44)	

Pipe Butt Weld End Connections

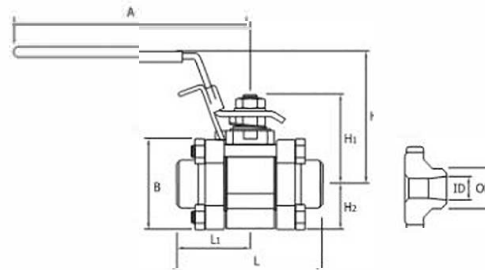

Basic Ordering number	End Connection	Orifice		Cv	Dimension mm (in.)									
		mm	in.		OD	ID	L	L1	H	H1	H2	A	B	
Schedule 10														
V83A-W4P10-	1/4 in.	7.1	0.271	1.2	13.70 (0.54)	10.40 (0.41)	52.4 (2.06)	26.20 (1.03)	47.7 (1.88)	31.8 (1.25)	16.75 (0.66)	57.2 (2.25)	33.0 (1.30)	
V83B-W8P10-	1/2 in.	13.1	0.516	15.0	21.30 (0.84)	17.10 (0.67)	68.9 (2.71)	34.45 (1.36)	64.8 (2.55)	44.2 (1.74)	22.25 (0.88)	111.0 (4.37)	44.5 (1.75)	
V83C-W12P10-	3/4 in.	22.2	0.875	36.0	26.67 (1.05)	22.45 (0.88)	92.0 (3.62)	46.00 (1.81)	79.0 (3.11)	61.9 (2.44)	31.00 (1.22)	149.4 (5.88)	62.0 (2.44)	
V83C-W16P10-	1 in.			40.0	33.40 (1.31)	27.90 (1.10)	88.9 (3.50)	44.45 (1.75)						
Schedule 40														
V83A-W4P40-	1/4 in.	7.1	0.271	1.2	13.70 (0.54)	9.20 (0.36)	52.4 (2.06)	26.20 (1.03)	47.7 (1.88)	31.8 (1.25)	16.75 (0.66)	57.2 (2.25)	33.0 (1.30)	
V83B-W8P40-	1/2 in.	13.1	0.516	15.0	21.30 (0.84)	15.80 (0.62)	68.9 (2.71)	34.45 (1.36)	64.8 (2.55)	44.2 (1.74)	22.25 (0.88)	111.0 (4.37)	44.5 (1.75)	
V83C-W12P40-	3/4 in.	22.2	0.875	36.0	26.67 (1.05)	20.93 (0.82)	92.0 (3.62)	46.00 (1.81)	79.0 (3.11)	61.9 (2.44)	31.00 (1.22)	149.4 (5.88)	62.0 (2.44)	
V83C-W16P40-	1 in.			40.0	33.40 (1.31)	26.60 (1.05)	88.9 (3.50)	44.45 (1.75)						
Schedule 80														
V83A-W4P80-	1/4 in.	7.1	0.271	1.2	13.70 (0.54)	7.70 (0.30)	52.4 (2.06)	26.20 (1.03)	47.7 (1.88)	31.8 (1.25)	16.75 (0.66)	57.2 (2.25)	33.0 (1.30)	
V83A-W6P80-	3/8 in.	7.1	0.281	3.8	17.10 (0.67)	10.70 (0.42)	68.9 (2.71)	34.45 (1.36)	64.8 (2.55)	44.2 (1.74)	22.25 (0.88)	111.0 (4.37)	44.5 (1.75)	
V83B-W8P80-	1/2 in.	10.4	0.411	7.5	21.30 (0.84)	13.90 (0.55)								
V83B-W12P80-	3/4 in.	13.1	0.516	13.6	26.70 (1.05)	18.80 (0.74)	88.9 (3.50)	44.45 (1.75)	79.0 (3.11)	61.9 (2.44)	31.00 (1.22)	149.4 (5.88)	62.0 (2.44)	
V83C-W16P80-	1 in.	22.2	0.875	40.0	33.40 (1.31)	23.90 (0.94)								



Swing-Out Ball Valves

V83 Series

External Vent Options

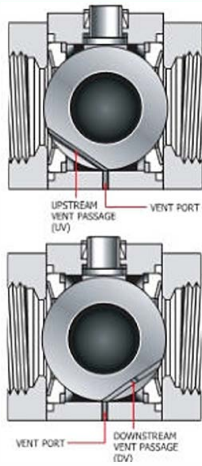

The vent passage is isolated from the ball bore. The valve in closed position, system fluids vent through vent passage to the vent port.
The valve in open position, no venting occurs, system fluids flow through the valve.
Choose either the Downstream Vent (DV) or Upstream Vent (UP) option.

External Vented Valve Rating

Upstream and downstream

Seat Material	Valve Series	Pressure, bar (psi)	Pressure @ Max. Temp.
Reinforced PTFE Virgin PTFE Carbon PTFE	V83A	68.9 (1000) @ -28 to 37°C (-20 to 100°F)	7 bar @ 232°C (100 psig @ 450°F)
	V83B		
	V83C		
PEEK	V83A		7 bar @ 232°C (100 psig @ 450°F)
	V83B		55 bar @ 232°C (800 psig @ 450°F)
	V83C		
UHMWPE	V83A	17 bar @ 121°C (250 psig @ 250°F)	
	V83B		
	V83C		

Maintenance Kits

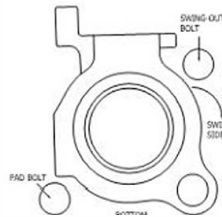
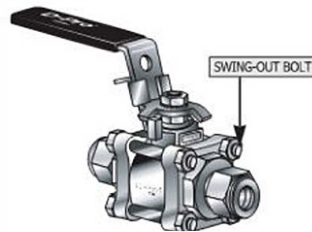

UnscREW the swing-out bolt and loosen other three bolts. This allows users to swing-out the body, keeping the valve in-line.

Seat Seal Kits

Kit contains each two pieces of seats, seat support rings, disc springs and flange seals.

Valve Series	Seat Material Designator	Flange Seal Designator
V83A- V83B- V83C-	Nil : Reinforced PTFE VP : Virgin PTFE CP : Carbon PTFE PK : PEEK UH : UHMWPE	Nil : Reinforced PTFE

To order, add - SEAT as a suffix to the ordering number. i.e., V83B-PK-SEAT

Flange Seal Kits

Kit contains two flange seals.

Valve Series	Flange Seal Designator	To order, add - FL as a suffix to the ordering number. i.e., V83A-FL
V83A- V83B- V83C-	Nil : Reinforced PTFE	

Packing Seal Kits

Kit contains each one piece of upper & lower packing, packing gland, packing support and stem bearing.

Valve Series	Packing Material Designator	Stem Bearing Designator
V83A- V83B- V83C-	Nil : Reinforced PTFE	PK : PEEK 7 : X750

To order, add - PKG as a suffix to the ordering number. i.e., V83B-PK-PKG

Fastener Kits

Kit contains each four pieces of body fasteners, body hex nuts and one stem nut.

Valve Series	Flange Seal Designator	To order, add - BOLT as a suffix to the ordering number. i.e., V83A-BOLT
V83A- V83B- V83C-	Gr.B8M	

- All dimensions shown in this catalog are for reference only and are subject to change.
- Dimensions with DK-Lok nuts are in finger-tight position.
- We reserve the right to change specifications stated in this catalog for our continuing program of improvement.

Safe Valve Selection

The selection of a valve for any application or system design must be considered to ensure safe performance. Valve function, valve rating, material compatibility, proper installation, operation and maintenance remain the sole responsibility of the system designer and the user. DK-Lok accepts no liability for any improper selection, installation, operation or maintenance.

P series Rack and Pinion Pneumatic Actuator



Model shown:

V83A single
V83A double
V83B double

A,B dimension

V83A: 40.71
V83B: 52.24

C dimension

V83A: 61.45
V83B: 65.62

Unit: mm

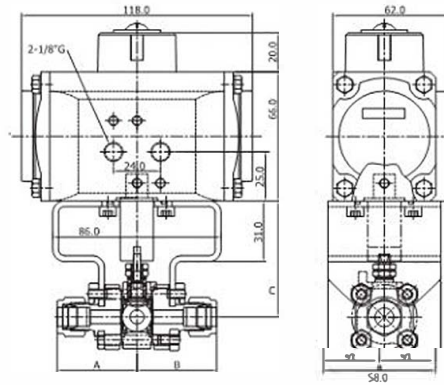

Actuator Material of Construction

Parts	Standard Material
Body	Extruded Aluminum Alloy with external & internal corrosion protection.
Piston (Rack)	Die Cast Aluminum Alloy Anodized.
Drive Shaft (Pinion)	Steel Alloy Nickel Plated.
Spring	Spring Alloy Steel Nickel Plated. (min. 5, max. 12 spring)
End Cap	Die Cast Aluminum Alloy Polyester Coated.
O-Ring	NBR is standard. Optional FKM and Silicon.

Table 1. Technical Information

- Actuator operating temperature (°C)
- Standard : NBR O-Ring -40 to 80.
 - Low Temperature : Silicon O-Ring -55 to 80 (Designator : LT).
 - High Temperature : FKM O-Ring -15 to 150 (Designator : HT).
 - Air-pressure : Min. 2.5 bar, Max. 8 bar.
 - Air supply end connection: Female G 1/8 inch (ISO 228-1).
 - Position indicator is standard.

Table 2. Single Return 90 Deg. Actuator

Valve series	Ordering Number		Dimensions L x H x W unit: mm	Weight Kg	Moment Values P=6 bar Nm	Air Consumption Liter	Mounting Bracket Ordering Number	Actuator Operating Temperature Options
	Normal Close	Normal Open						
V83A	PCS1	POS1	118x86x62	0.9	3.5	0.10	V83A-SMB	Nil: Standard Temp.
V83B	PCS3	POS3	140.5x89x70.5	1.13	7.4	0.15	V83B-SMB	LT: Low Temp.
V83C	PCS4	POS4	210.5x122x94.5	3.09	17.7	0.49	V83C-SMB	HT: High Temp.

Table 3. Double Return 90 Deg. Actuator

Valve series	Ordering Number	Weight Unit: Kg	L x H x W unit: mm	Moment Values	Air Consumption	Mounting Bracket Ordering Number	Mounting Bracket Ordering Number
				P=6bar Nm	Liter		
V83A	PD1	0.75	118x86x62	14.4	0.10	V83A-DMB	Nil: Standard Temp.
V83B	PD1	0.75	118x86x62	14.4	0.10	V83B-DMB	LT: Low Temp.
V83C	PD2	1.03	140.5x89x70.5	19.9	0.15	V83C-DMB	HT: High Temp.

Mount bracket : Field assembly kit includes mount bracket, valve to actuator connector, special size of valve body fasteners, fastener washers, bracket bolts and assembly manual.

How to Order

Select applicable valve pattern, seat options, pneumatic actuator, and the actuator temperature option from designator listed below.

V83A-D4T	- PK				-PCS1	-HT	-S
V83C-D25M		- 7			-PD2		-S
Seat Material	Stem Bearing	Flange Seals	External Vent	Handle	Factory Assembled Actuator	Actuator Temperature Options	Body & Flange Material
Nil : Reinforced PTFE VP : Virgin PTFE CP : Carbon PTFE PK : PEEK UH : UHMWPE	Nil : PEEK 7 : X750	Nil : Standard PTFE	UV : External Upstream DV : External Downstream	Nil : Lever Handle OH : Oval Handle	• Single return, see Table 2. • Double return, see Table 3.	Nil : Standard Temp. LT : Low Temp. HT : High Temp.	S : A351 CF8M L : A351 CF3M C : A216 Gr. WCB