



# SERIES 35 DIAPHRAGM VALVES

F-F: EN558-1 Series 7 BS 5156



KDV's range of bi directional Weir Type diaphragm valves offer exceptional durability and reliability. The clean design completely isolates line media from the mechanical components of the valve. Bubble tight shutoff (Class VI) and in-line serviceability (top entry) maximise plant efficiency and productivity.

KDV Weir Type diaphragm valves are suited to on-off and control applications and can be custom specified to suit a wide variety of applications.

*Contact your KDV technical sales representative to ascertain the correct valve and lining options for your specific application.*

## Designed & Manufactured by KDV

KDV Diaphragm valves are manufactured to international standards. Precision machining and strict quality control ensure consistency, reliability and durability.

## COMMON APPLICATIONS

- Acid (e.g. hydrochloric, sulphuric nitric)
- Moist chlorine
- Chlorinated water
- Demineralised water
- Salts
- Caustic solutions
- Lime solutions
- Copper chemicals

## IDEAL FOR INORGANIC BASED SOLUTIONS

### RUBBER LINING OPTIONS & IDENTIFICATION

Lined valves are identified with a flash of colour on the valve body

- |                                              |                                            |                                           |
|----------------------------------------------|--------------------------------------------|-------------------------------------------|
| <input type="checkbox"/> HARD RUBBER (White) | <input type="checkbox"/> BUTYL (Red)       | <input type="checkbox"/> EPDM (Pink)      |
| <input type="checkbox"/> SOFT RUBBER (Blue)  | <input type="checkbox"/> NEOPRENE (Yellow) | <input type="checkbox"/> HYPALON (Purple) |

## FEATURES & BENEFITS

- Bubble-tight shutoff
- Easy/low maintenance
- Readily available spare parts
- In-line serviceable (top entry)
- Cavity free design
- Position indicator
- Excellent control characteristics
- Low fugitive emissions
- No stem seal leakage
- Line media isolated from valve mechanicals

## OPERATOR OPTIONS

- Lockable device (for isolation)
- Sealed bonnet
- Extension spindle
- Chain wheel
- Stainless steel bonnet
- Plastic bonnet (DN15-DN50)

## AUTOMATION SYSTEMS

- Pneumatic (fail open, fail closed, double acting)
- Electric
- Hydraulic

## OPTIONS

- Flange drilling standards: ANSI, BS, DIN, JIS
- Range of body materials
- Specialty coatings to suit a variety of environmental requirements
- Range of bonnet materials

## FAST TRACK

In house manufacture and stock holdings allow KDV to deliver quickly, and reliably facilitate fast-track projects. Visit our website for information on the full range of KDV Diaphragm Valves.



## MATERIALS OF CONSTRUCTION

PART	MATERIAL
1 Body	Cast Iron, Cast Ductile Iron, WCB, Stainless Steel
1a Lining	See Below <sup>1</sup>
2 Diaphragm	See Below <sup>2</sup>
3 Bonnet Shell	Cast Iron, Cast Ductile Iron
4 Hand Wheel	Cast Iron, Ductile Iron (Coatings and alternative materials on request)
5 Spindle	SS304, SS316
6 Compressor	Cast Iron, Cast Ductile Iron
7 Fasteners	ISO Grade 8.8, Stainless Steel
8 Hand Wheel Pin	Spring Steel
9 Thrust Disc	Delrin
10 Environmental Seal	EPDM Wiper Seal

## DIMENSIONS & WEIGHTS (F-F EN558-1 Series 7 BS 5156)

Valve	L (mm)	A (mm)	H (mm)	Weight (kg)
DN15	114	110	64	1.9
DN20	123	122	65	2.5
DN25	133	131	87	3.6
DN32*	152	143	124	6.1
DN40	165	169	123	7.2
DN50	196	199	123	9.3
DN65*	222	231	185	14.8
DN80	260	250	225	20.7
DN100	313	325	275	34.6
DN125*	364	389	360	47.0
DN150	414	457	355	74.9

\*Environmental seal not available for DN32, DN65 & DN125

## PRESSURE RATING

Elastomer diaphragms		PTFE diaphragms	
DN15 - DN50	16 Bar	DN15 - DN50	10 Bar
DN65 - DN125	10 Bar	DN65 - DN125	10 Bar
DN150	10 Bar	DN150	7 Bar

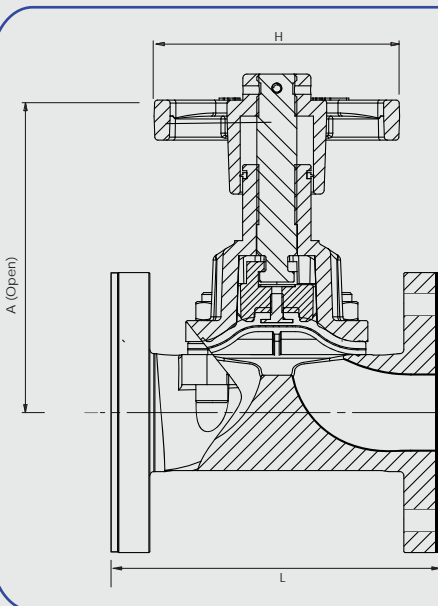
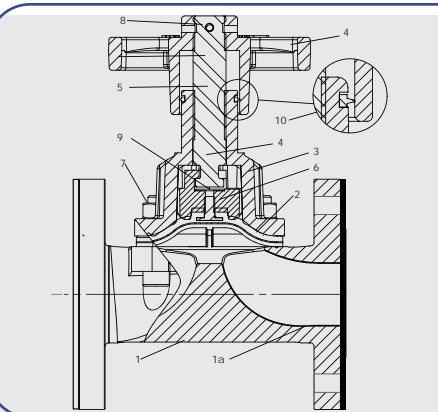

## DIAPHRAGM MATERIALS<sup>2</sup>

- 10 - Natural rubber (NR)
- 20 - EPDM rubber
- 30 - Butyl rubber (IIR)
- 40 - Nitrile rubber (NBR)
- 50 - Neoprene rubber (CR)
- 60 - Hypalon rubber (CSM)
- 70 - Viton rubber (FKM/FPM)
- 92 - PTFE/EPDM backed
- 93 - PTFE/Butyl backed
- 96 - PTFE/Hypalon backed
- 97 - PTFE/Viton backed
- 98 - PTFE/Silicon backed
- 9D - TFM/PVDF/EPDM (3 PIECE)
- 9R - TFM/PVDF/EPDM (3 PIECE with titanium Connector)

NB: Vacuum grade diaphragms available on request

## RUBBER THICKNESS

- DN15 - DN80 : 3mm
- DN100 - DN150 : 4mm

## MATERIAL SPECIFICATIONS

- Cast Iron (ASTM A126 Gr CI B)
- Cast Ductile Iron (ASTM A395 Gr 60-40-18)
- Carbon Steel (ASTM A216 Gr WCB)
- Stainless Steel (ASTM A351 Gr CF8, CF8M, CF3, CF3M)

## FLANGE DRILLING STANDARDS

- ANSI B16.5 Class 125 & 150 FF
- EN1092 (PN10/16) (BS4504) FF
- AS2129-2000 Table D/E (BS10 1962)
- JIS B2220

## DESIGN STANDARDS

- EN13397-2001 (BS5156:1985)
- MSS SP88-1993-(R-01)

## FACE TO FACE STANDARDS

- EN558-1 Series 7(BS5156)
- EN558-1 Series 1(DIN3202-F1)
- MSS SP88-1993-(R-01)

## TESTING STANDARDS

- EN12266-1 2002(BS6755 Part 1)
- MSS SP88-1993-(R-01)

## LINING OPTIONS<sup>1</sup>

- Hard Rubber
- Soft Rubber
- EPDM
- Butyl
- Neoprene
- Hypalon

Note 1: Specifications contained in this document are subject to change.  
Note 2: For precise specifications and dimensions contact KDV to obtain a general assembly drawing.