

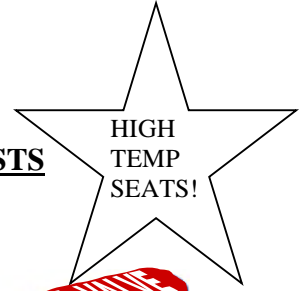

VALVE AND FLOW CONTROL SPECIALISTS
SERVICE AND RELIABILITY



STAINLESS STEEL 3 PIECE BALL VALVE

FIGURE NO. VBL-S1003TFM

3 - PC BALL VALVES. FULL PORT. 1000 WOG

End Type : Threaded end. Socket weld end. Butt-weld end

Materials : ASTM A351-CF8M (DIN 1.4408) Stainless Steel

- * High quality investment casting body caps.
- * Bolted / in line easy maintenance
- * Pressure temperature rating : 1/4"-2" 1000 PSI CWP. Max 250 deg.C
- * TFM seats (2nd generation High Temp Teflon) , in-line repairable.
- * Blow-out proof stem S/S 316, adjustable stem packing.
- * 100% Tested air-under water at 100psi
- * (6 Bars) open & close position

OPTIONS :

- * Padlocking Handle. Pneumatic Actuator or Electric Actuator.
- * Mounting Bracket & Extension Shaft. Spare seats stocked

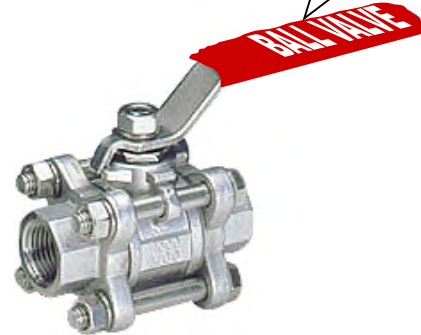

MODEL NO : VBL-S1003TFM
SIZE : 1/4"-4"FULL BORE
THREADED END : BSPT

MATERIAL LIST

NO.	PART NAME	MATERIAL	QTY
1	BODY	CF8M	1
2	CAP	CF8M	2
3	BALL	AISI 316	1
4	SEAT	TFM	2
5	STEM	AISI 316	1
6	THRUST PACKING	TEFLON	1
7	STEM PACKING	TEFLON	3
8	LOCK WASHER	AISI 304	4
9	GLAND NUT	AISI 304	4
10	BONNET	AISI 304	4
11	HEX.NUT	AISI 304	1
12	LOCK WASHER	AISI 304	1
13	STEM NUT	AISI 304	1
14	HANDLE	AISI 304	1
15	PLASTIC COVER	PLASTIC	1

The TFM seats not only give a higher pressure / temperature curve than standard RTFE they also reduce the effect of seat flow commonly found in ball valves today when used on "hot" service. With lower friction it also makes the valves easier to operate at elevated temperatures.

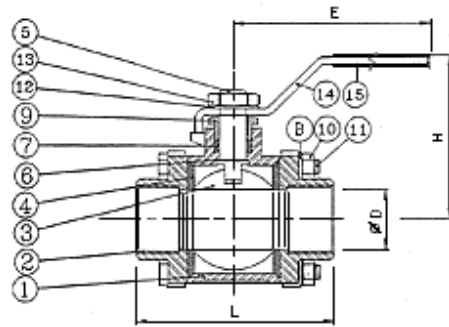

DIMENSIONS (MM)

SIZE	ØD ±0.5	L ±1.0	H ±3.0	E ±3.0	WT/KG	INCH/LBS
1/4"	11.6	57	50.5	100	0.40	30
3/8"	13	57	50.5	100	0.40	30
1/2"	16	73	60	130	0.60	36
3/4"	20.6	74	64	130	0.80	54
1"	25.4	85	71	165	1.05	64
1 1/4"	32	120	78	165	1.80	132
1 1/2"	38	122	86	190	2.50	156
2"	50.8	130	95	190	3.85	192
2 1/2"	65	170	130	250	8.1	250
3"	80	185	149	250	13.4	400
4"	100	232	184	280	24.50	720

2012 Uncontrolled copy subject to change without notice.

Valve & Flow Control Specialists Pty Ltd. sales@valveandflowcontrolspecialists.com