

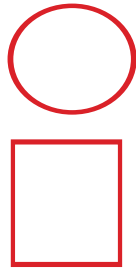

**VALVE AND FLOW CONTROL SPECIALISTS**  
*SERVICE AND RELIABILITY*



**i-TORK®**

**Electric Actuator  
MULTI-TURN**

## **ITM Series**

**0180 / 0450 / 0750 / 1800 / 3000**



Valve and Flow Control Specialists  
BRISBANE - SYDNEY - MELBOURNE - DARWIN  
Email: [sales@valveandflowcontrolspecialists.com](mailto:sales@valveandflowcontrolspecialists.com)

With many years of experience with wide range of products used in the Valve Automation field. I-TORK® has achieved successful reputation and technical improvement to take another step forward once again.

“I-TORK® Controls Ltd.”, are pleased to introduce our Multi-turn Electric Actuator the ‘ITM Series’.

Following on from our well-known Quarter-turn Electric Actuator the ‘ITQ Series’. Our ITM Series is expected to be a valued addition to our range of industrial valve automation products with the same proven reliability as our Quarter-turn ‘ITQ Series’.

We are now able to provide our customers with the complete actuators solution, whether it is a Quarter-turn or a Multi-turn solution that is required.

Meeting with our customers needs and requirements is our top priority.

Rest assured that our After Sales service is second to none.

We stand behind our products 100%.

### **Main Application Fields**

ENERGY : Petrochemical/Oil-Refining Facilities, Power Plants, District Heating Systems,

WATER TREATMENT : Filtration, Sewage Disposal Plants, Reservoirs, Pump Stations, Sluice Gates, Dams,

CHEMICAL PLANT : Pharmaceutical Factories, Various Industrial Plants,

OTHERS : Steel Mills, Cement Factories, Shipbuilding (Ship-Yards), Food Factories, HVAC, and so on.





### General Information

- High efficiency & torque motor with thermal protectors
- Digitalized torque sensing system  
(adjustable range: 30% - 100%)
- Precisely machined gearing system & oil lubrication
- Top-mounted hand-wheel for easy operation
- Battery back-up for position detecting system
- Integrated local control unit
- 52-pin terminal block
- Mounting base according to ISO5210
- Bushing for adapting valve stem
- Remote control for setting device/tool
- IP68 Enclosure (10m for 100hrs in water)

### STANDARD SPECIFICATIONS

- \*MAIN POWER : 3PH, AC 220/380/400/415/440/460/480 V, 50/60Hz ( $\pm 10\%$ )
- \*MOTOR : TENV, External Cooling Pin, Insulation Class: F, Thermostat,
- \*REMOTE MONITORING SWITCH :  
Standard-8EA (S1-S8, LATCH, AC250V 2A), Other-1EA (FAULT, 1C)
- \*INDICATION ON LOCAL CONTROL PANEL :  
Graphic LCD, 4-LED (Power, Fault, Close, Open)
- \*TERMINAL : Double Sealing Structure with O-ring
  - CONTROL : 48 Contacts/M4 (Voltage rated: AC250V 5A)
  - POWER : 4 Contacts/M5 (Voltage rated: AC660V 63A)
- \*ENCLOSURE : IP68 (10m for 100hrs in water)
- \*SPACE HEATER : 10W, DC 24V
- \*OPERATIONAL TEMPERATURE :  $-20^{\circ}\text{C} \sim 70^{\circ}\text{C}$
- \*MANUAL HAND-WHEEL : Top-mounted, directly connected to drive sleeve,  
switching lever (manual-electric) with automatic reset
- \*CABLE ENTRY : 1 - PF1 1/2", 2 - PF1"
- \*LOCAL CONTROL PANEL :  
Selector Switch for OPEN/CLOSE, Selector Switch for REMOTE/STOP/LOCAL
- \*STANDARD PAINTING : Liquified Paint

### OPTION

- \*REMOTE SIGNAL TRANSMITTER : CT (Current Transmitter) (Output: 4-20mA)
- \*MODULATING : RPC (Remote Position Controller)
  - INPUT SIGNAL : 4-20mA, 0-10VDC, 2-10VDC, 0-5VDC, 1-5VDC
  - OUTPUT SIGNAL : 4-20mA (Option: 0-10VDC)
- \*FIELD BUS : Profibus, CANopen, other Bus communication protocol types available
- \*EXPLOSION-PROOF : Ex d IIC T4

### MANUAL HAND-WHEEL AND SWITCHING LEVER

Top-Mounted Hand-wheel for easy manual operation  
No-interruption structure while installing actuator  
Simple switching from electric to manual (by switching lever even when the motor is running)  
Automatic switching from manual to electric (if the motor is running by electricity)

### BATTERY HOLDER

Battery : U9VL (9V, 1200mAh)  
LITHIUM/Manganese Dioxide Designation  
NEDA 1604LC

### MOTOR (TENV Type)

TENV (Totally Enclosed Non-Ventilated) Type  
Insulation Class: F, Thermostat installed, Standard Rating : 15min.  
Voltage: available within +/-10%  
Large torque Motor with a large output starting torque  
Radiating Cooling Plate to maximize radiation effect  
in high temperature during abnormal operation  
Motor is mounted in easy-detachable structure  
(for easy replacement if damaged)

### DECELERATOR / REDUCTION-GEAR

Highly efficient 'single reduction gear (worm)' ensures low noise  
Higher efficiency compared to multi-level gearing

### TERMINAL UNIT

Double sealing structure with O-ring  
to protect the inside of the actuator  
when terminal cover is open  
Rigid outer wiring

### CABLE ENTRY

Various types available

### LUBRICANT

Oil lubrication of worm reduction gear  
Stable operation ensured even in extremely low temperature

### THRUST UNIT

Detachable, as separate from the actuator main body for easy installation  
Ductile material, Drive bushing and Thrust bearing  
Drive Bushing: two (2) types for Quarter-turn and Multi-turn

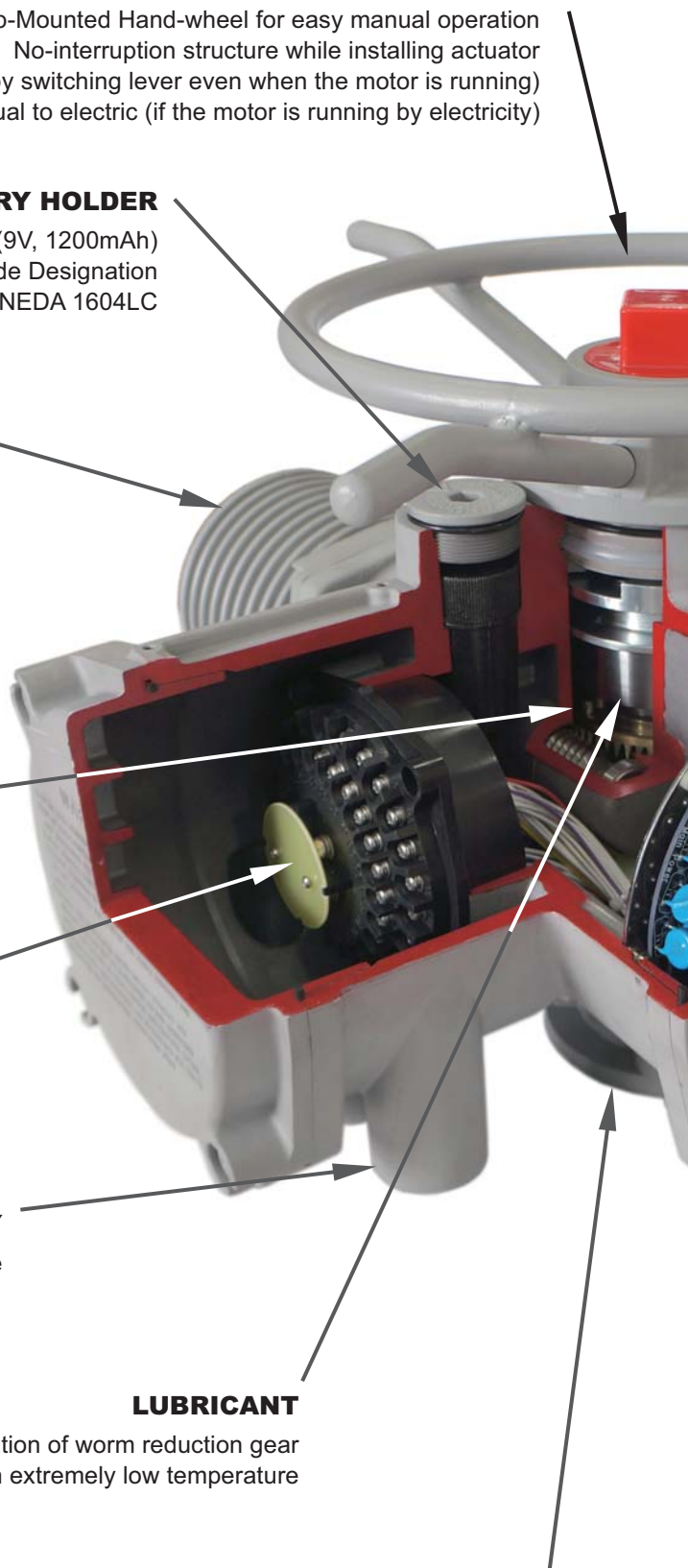

**POSITION DETECTING SWITCH**

Hall Incremental Encoder developed by I-TORK to ensure accurate valve position detection, Valve position memorized and recorded accurately even without power supply

**SPACE HEATER**

Ensured anti-condensation

**LOCAL CONTROL**

All selector switches : non-penetration type and complete separation to ensure insulation with internal circuit, Remote Control and Selector Switches to ensure easy setting and checking of the actuator condition (no need to open local control cover), Water-proof

- Operating Selector Switch:  
Open/Close, Remote/Stop/Local, Indication and Setting on LCD display, Remote Control Receiver
- Integral Unit:  
Automatic Phase Change, Negative/Open Phase Protection, Transformer, Magnetic Contactor, CPU Card, Relay Card

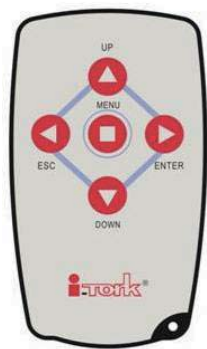
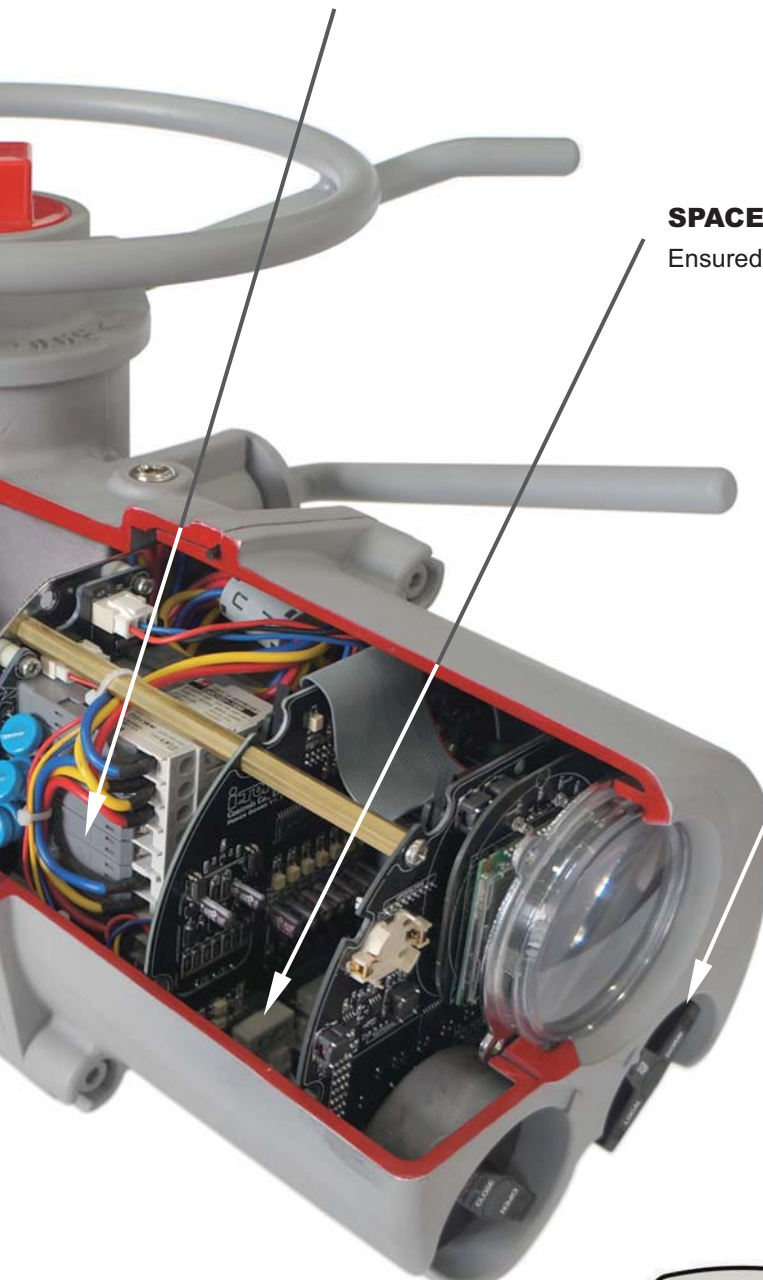

**REMOTE CONTROL**

Up/Down/ESC/Enter/Menu, Weather-proof (up to IP67)  
Size : 80 x 46 x 11.2mm  
Power : 3.0V DC, CR2025 x 1pcs

<b>MAIN POWER</b>	3PH, AC 220/380/400/415/440/460/480V, 50/60Hz, (±10%)
<b>CONTROL POWER</b>	INTERNAL POWER: DC 24V EXTERNAL POWER: AC/DC 24V~48V EXTERNAL POWER: AC 110V, 1PH EXTERNAL POWER: AC 220V, 1PH
<b>LOCAL CONTROL</b>	OPEN/CLOSE LOCAL/STOP/REMOTE - SELECTABLE
<b>INTERLOCK</b>	INCHING / HOLDING NORMAL (CW=CLOSE) / REVERSE (CCW=CLOSE)
<b>STATUS (DRY CONTACT : N/O)</b>	OPENING (LATCH, *N/O, N/C) FULL OPEN (LATCH, *N/O, N/C) CLOSING (LATCH, *N/O, N/C) FULL CLOSE (LATCH, *N/O, N/C) CLOSE OVER TORQUE (LATCH, *N/O, N/C) OPEN OVER TORQUE (LATCH, *N/O, N/C) REVERSE 3PH (LATCH, *N/O, N/C) LOCAL / REMOTE STATUS (LATCH, *N/O, N/C) POWER FAIL (N/C) (*I-TORK Standard)
<b>PROTECTION</b>	From Reversed-Phase and Open-Phase Auto-Phase Discriminator or Phase-Protection Motor Protection with built-in TP in the motor
<b>ESD (EMERGENCY SHUTDOWN)</b>	User can select the status of the actuator when ESD signal is detected; CLOSE / STOP / OPEN
<b>MODULATION</b>	INPUT SIGNAL: DC 4-20mA / DC 0-5V / DC 0-10 / DC 1-5V / DC 2-10V FAIL SAFE POSITION: CLOSE / STOP / OPEN (When Input Signal Lost) OUTPUT SIGNAL: DC 4-20mA
<b>DISPLAY</b>	LCD: 128 x 64 Graphic LCD 4 LEDs POWER : WHITE FAULT : YELLOW CLOSE : GREEN OPEN : RED

<b>ITM</b>	<b>180</b>	<b>450</b>	<b>750</b>	<b>1800</b>	<b>3000</b>
<b>BODY TYPE</b>	TOP HANDLE			SIDE HANDLE	
<b>GEARING</b>	WORM GEAR				
<b>ENCLOSURE</b>	IP-68				
<b>EXPLOSION PROOF</b>	Ex d II C T4 (Optional)				
<b>MAX TORQUE (Nm/Kg.m)</b>	177/ 18	441 / 45	735 / 75	1,765 / 180	2,942 / 300
<b>rpm 50/60Hz</b>	12/14, 16/19, *23/28, 32/38, *48/57, *73/87, *98/118				
<b>STEM Ø KEY</b>	Ø 35	Ø 50	Ø 60	Ø 95	Ø 115
<b>STEM SCREW</b>	TW40	TW60	TW72	TW110	TW130
<b>FLANGE (ISO 5210)</b>	F10	F14	F16	F25	F30
<b>DECLUTCHING</b>	AUTO				
<b>TORQUE SWITCHES</b>	TORQUE SENSOR				
<b>LIMIT SWITCHES</b>	HALL INCREMENTAL ENCODER				
<b>DISPLAY</b>	128 X 64 Graphic LCD / 4-LED				
<b>DUTY CYCLE</b>	S2 : 15min (Option - S4 : 30~50%)				
<b>MOTOR CLASS (INSULATION)</b>	F				
<b>MAIN POWER</b>	3PH, AC 220/380/400/415/440/460/480V, 50/60Hz (±10%)				
<b>AMBIENT TEMPERATURE</b>	-20°C ~ 70°C				
<b>TERMINAL</b>	52 PIN			75 PIN	
<b>CABLE ENTRIES</b>	*1-PF 1-1/2", NPT 1-1/2" *2 - PF 1", 2 - NPT 1"			4 - PF 1", 4 - NPT 1"	
<b>BODY MATERIAL</b>	ALUMINUM ALLOY				
<b>LUBRICATION</b>	GREASE (EP-000)				

\*I-TORK Standard



(\*STANDARD)

MODEL	RPM 50/60Hz	12/14	16/19	*23/28	32/38	*48/57	*73/87	*98/118	
	Motor (Kw)	Max. Torque (Nm / Kgf.m)							
ITM 0180	0.2	Nm	83.4 / 69.6	62.8 / 52.0	43.1 / 34.3	55.9 / 47.1	38.2 / 31.4	33.3 / 27.5	27.5 / 22.6
		Kgf.m	8.5 / 7.1	6.4 / 5.3	4.4 / 3.5	5.7 / 4.8	3.9 / 3.2	3.4 / 2.8	2.8 / 2.3
	0.4	Nm	167 / 139	125 / 104	85.3 / 68.6	112 / 93.2	76.5 / 61.8	67.7 / 25.5	54.9 / 44.1
		Kgf.m	17.0 / 14.2	12.7 / 10.6	8.7 / 7.0	11.4 / 9.5	7.8 / 6.3	6.9 / 2.6	5.6 / 4.5
	0.75	Nm	177 / 177	177 / 177	161 / 129	177 / 177	114 / 116	127 / 101	103 / 82.4
		Kgf.m	18.0 / 18.0	18.0 / 18.0	16.4 / 13.2	18.0 / 18.0	14.7 / 11.8	12.9 / 10.3	10.5 / 8.4
ITM 0450	0.75	Nm	326 / 273	244 / 204	168 / 134	226 / 188	155 / 125	128 / 103	103 / 82.4
		Kgf.m	33.2 / 27.8	24.9 / 20.8	17.1 / 13.7	23.0 / 19.2	15.8 / 12.7	13.1 / 10.5	10.5 / 8.4
	1.5	Nm	441 / 441	441 / 408	335 / 270	441 / 377	309 / 249	256 / 206	206 / 166
		Kgf.m	45.0 / 45.0	45.0 / 41.6	34.2 / 27.5	45.0 / 38.4	31.5 / 25.4	26.1 / 21.0	21.0 / 16.9
	2.2	Nm	441 / 441	441 / 441	441 / 395	441 / 441	441 / 365	376 / 303	302 / 243
		Kgf.m	45.0 / 45.0	45.0 / 45.0	45.0 / 40.3	45.0 / 45.0	45.0 / 37.2	38.3 / 30.9	30.8 / 24.8
ITM 0750	1.5	Nm	624 / 523	468 / 390	321 / 259	428 / 357	293 / 236	252 / 203	209 / 169
		Kgf.m	63.6 / 53.3	47.7 / 39.8	32.7 / 26.4	43.6 / 36.4	29.9 / 24.1	25.7 / 20.7	21.3 / 17.2
	2.2	Nm	735 / 735	686 / 573	471 / 380	627 / 524	430 / 346	370 / 297	307 / 247
		Kgf.m	75.0 / 75.0	70.0 / 58.4	48.0 / 38.7	63.9 / 53.4	43.8 / 35.3	37.7 / 30.3	31.3 / 25.2
	3.7	Nm	735 / 735	735 / 735	735 / 637	735 / 735	723 / 582	621 / 500	517 / 416
		Kgf.m	75.0 / 75.0	75.0 / 75.0	75.0 / 65.0	75.0 / 75.0	73.7 / 59.3	63.3 / 51.0	52.7 / 42.4
ITM 1800	3.7	Nm	1,677 / 1,402	1,255 / 1,049	863 / 693	1,079 / 901	740 / 596	633 / 509	508 / 409
		Kgf.m	171 / 143	128 / 107	88.0 / 70.7	110 / 91.9	75.5 / 60.8	64.5 / 51.9	51.8 / 41.7
	5.5	Nm	1,765 / 1,765	1,765 / 1,559	1,275 / 1,030	1,608 / 1,344	1,098 / 886	939 / 757	755 / 608
		Kgf.m	180 / 180	180 / 159	130 / 105	164 / 137	112 / 90.3	95.8 / 77.2	77.0 / 62.0
	7.5	Nm	1,765 / 1,765	1,765 / 1,765	1,746 / 1,402	1,765 / 1,765	1,500 / 1,206	1,285 / 1,030	1,030 / 829
		Kgf.m	180 / 180	180 / 180	178 / 143	180 / 180	153 / 123	131 / 105	105 / 84.5
ITM 3000	7.5	Nm	2,942 / 2,942	2,942 / 2,550	2,089 / 1,687	2,001 / 1,667	1,373 / 1,108	1,353 / 1,089	1,079 / 869
		Kgf.m	300 / 300	300 / 260	213 / 172	204 / 170	140 / 113	138 / 111	110 / 88.6
	11	Nm	2,942 / 2,942	2,942 / 2,942	2,560 / 2,059	2,932 / 2,452	2,010 / 1,618	1,677 / 1,353	1,344 / 1,079
		Kgf.m	300 / 300	300 / 300	261 / 210	299 / 250	205 / 165	171 / 138	137 / 110
	15	Nm	2,942 / 2,942	2,942 / 2,942	2,942 / 2,805	2,942 / 2,942	2,746 / 2,206	2,285 / 1,844	1,824 / 1,471
		Kgf.m	300 / 300	300 / 300	300 / 286	300 / 300	280 / 225	233 / 188	186 / 150



<b>MODEL</b>	<b>TORQUE (Nm / kgf . m)</b>	<b>ALLOWABLE THRUST [ton / kN]</b>	<b>STEM DIAMETER (mm) Key / Threaded</b>	<b>FLANGE ISO No. TAP PCD SIZE (mm)</b>	<b>Weight (Kg)</b>
<b>ITM 0180</b>	177 / 18	7 / 68.6	35 / 40	125 F10 102 4 - M10 70	40
<b>ITM 0450</b>	441 / 45	12 / 118	50 / 60	175 F14 140 4 - M16 100	60
<b>ITM 0750</b>	735 / 75	16 / 157	60 / 72	210 F16 165 4 - M20 130	89
<b>ITM 1800</b>	1,765 / 180	40 / 392	95 / 110	300 F25 254 8 - M16 200	185
<b>ITM 3000</b>	2,942 / 300	70 / 686	115 / 130	350 F30 298 8 - M20 230	210



# DIMENSIONS

# MULTI-TURN ACTUATOR ITM SERIES

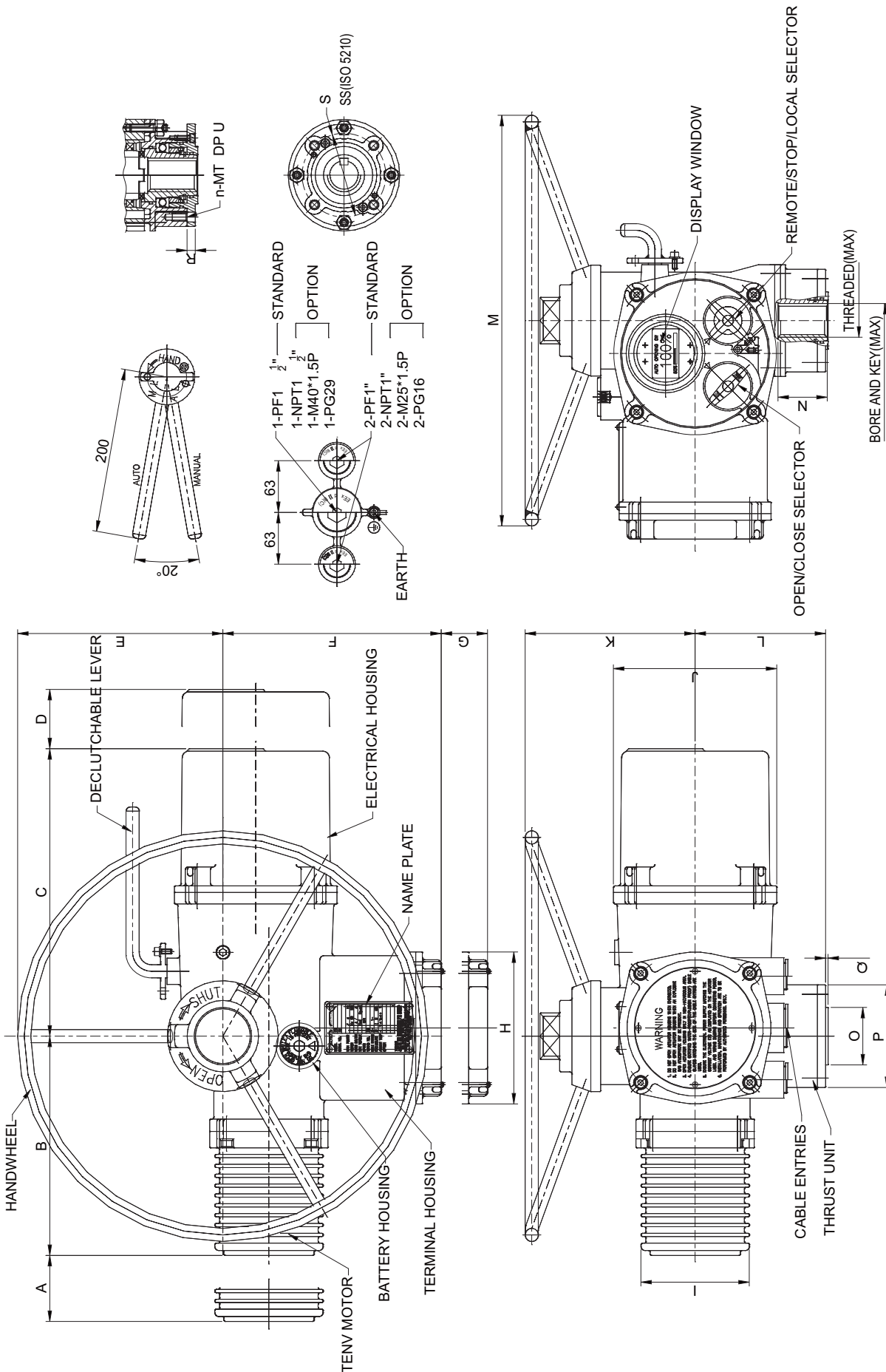

MODEL	A	B	C	D	E	F	G	H	I	J	K	L	M	N	O	P	Q	R	S	SS	n-MT DP U	BORE AND KEY	THREADED
ITM0180	185	267	350	210	250	266	120	185	132	199	207	159	150	60	70	125	3	10	102	F10	4-M10 DP18	35(MAX)	40(MAX)
ITM0450	230	330	364	210	275	286	120	185	162	199	227	193	150	80	100	175	4	13	140	F14	4-M16 DP30	50(MAX)	60(MAX)
ITM0750	260	392	376	210	320	316	120	185	184	199	256	209	160	95	130	210	5	16	165	F16	4-M20 DP36	60(MAX)	72(MAX)

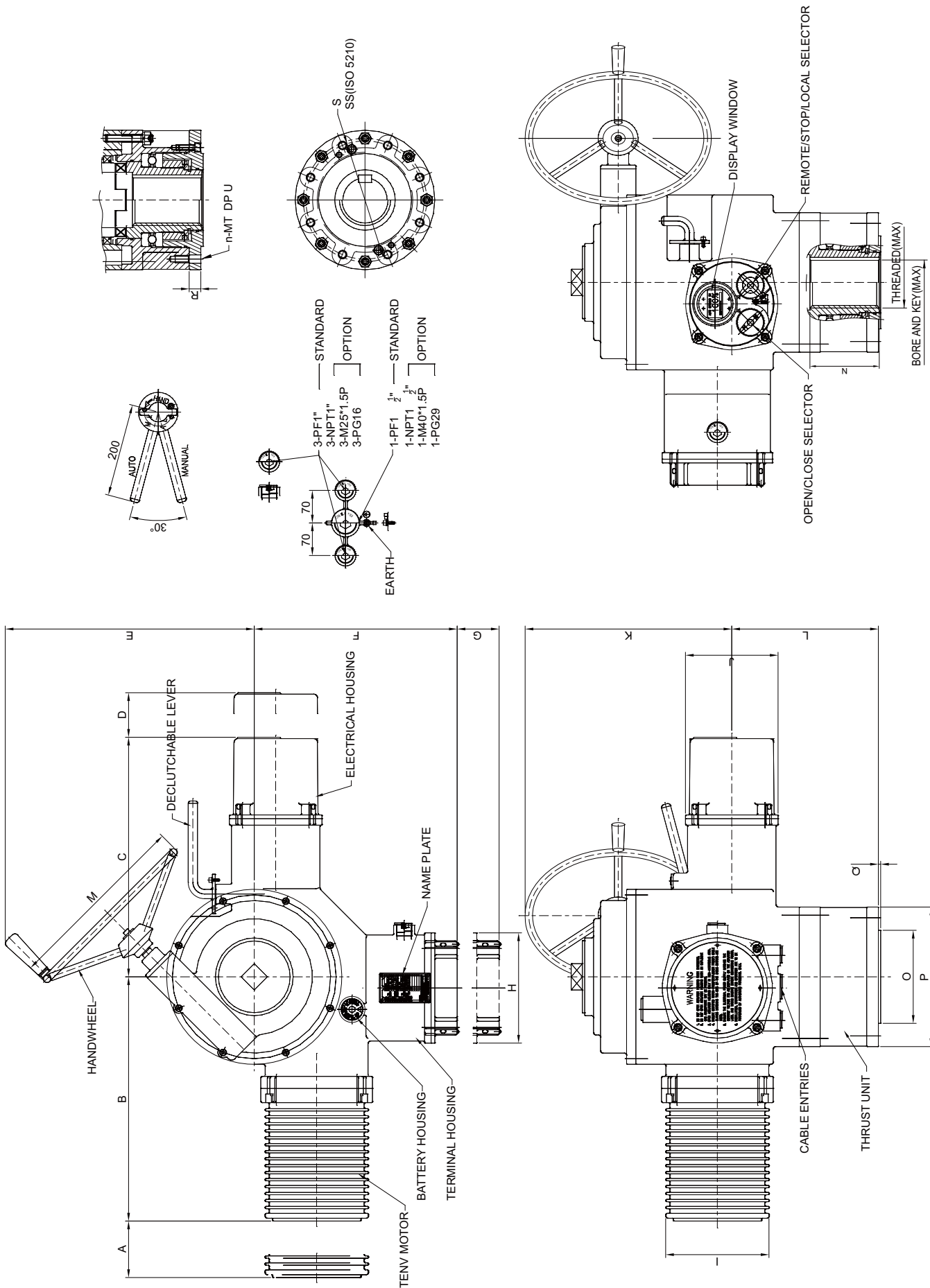

MODEL	A	B	C	D	E	F	G	H	I	J	K	L	M	N	O	P	Q	R	S	SS	n-MT DP U	BORE AND KEY	THREADED
ITM01800	310	525	515	210	535	436	120	237	222	199	444	315	400	149	200	300	5	25	254	F25	8-M16 DP30	95(MAX)	110(MAX)
ITM03000	360	604	535	210	579	496	120	237	259	199	481	344	400	171	230	350	5	30	298	F30	8-M20 DP36	115(MAX)	130(MAX)

# WIRING DIAGRAM

# MULTI-TURN ACTUATOR ITM SERIES

**OPTION NAME : BASIC**

1	FGND					
2	MOTOR POWER 3PH "U"					
3	MOTOR POWER 3PH "V"					
4	MOTOR TP	16	S2 : OLS*	28		
5	N.C*	17	FULL OPEN (LATCH, N.O* / N.C)	29		
6	CLS	18	S3 : CTS*	30		
7	CLOSE LIMIT RELAY (LATCH, N.O / N.C*)	19	CLOSE TORQUE (LATCH, N.O* / N.C)	31		
8	OLS	20	S4 : OTS*	32		
9	OPEN LIMIT RELAY (LATCH, N.O / N.C*)	21	OPEN TORQUE (LATCH, N.O* / N.C)	33		
10	CTS	22	INCOMING CONTROL POWER FAIL/READY, COM	34		
11	CLOSE TORQUE RELAY (LATCH, N.O / N.C*)	23	INCOMING CONTROL POWER OFF, FAIL	35		
12	OTS	24	INCOMING CONTROL POWER ON, READY	36		
13	OPEN TORQUE RELAY (LATCH, N.O / N.C*)	25		37		
14	S1 : CLS*	26		38		
15	FULL CLOSE (LATCH, N.O* / N.C)	27		39		
				40		
				41		
				42		
				43		
				44		
				45		
				46		
				47		
				48	24V+	INCOMING CONTROL POWER
				49	24V-	DC 24V
				50	LIVE	INCOMING CONTROL POWER
				51	NEUTRAL	AC 87V~264V

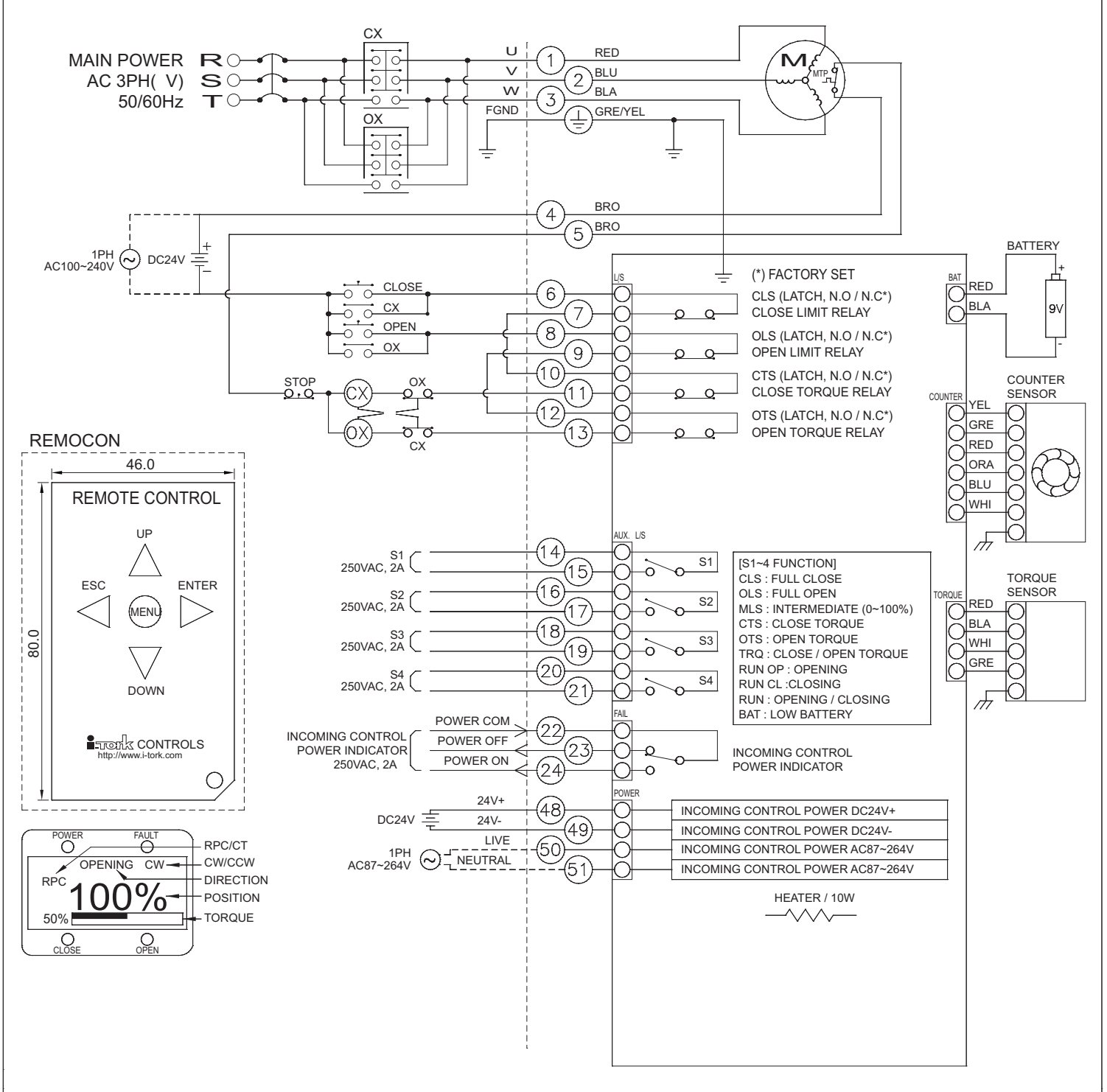

OPTION NAME : BASIC + RPC

1	FGND				
2	MOTOR POWER 3PH "U"				
3	MOTOR POWER 3PH "V"				
4	MOTOR TP	16	S2 : OLS*	28	
5	N.C*	17	FULL OPEN (LATCH, N.O* / N.C)	29	
6	CLS	18	S3 : CTS*	30	
7	CLOSE LIMIT RELAY (LATCH, N.O / N.C*)	19	CLOSE TORQUE (LATCH, N.O* / N.C)	31	
8	OLS	20	S4 : OTS*	32	
9	OPEN LIMIT RELAY (LATCH, N.O / N.C*)	21	OPEN TORQUE (LATCH, N.O* / N.C)	33	CLOSE RELAY, RPC OUTPUT COMMAND
10	CTS	22	INCOMING CONTROL POWER FAIL/READY, COM	34	COM, RPC OUTPUT COMMAND COMMON
11	CLOSE TORQUE RELAY (LATCH, N.O / N.C*)	23	INCOMING CONTROL POWER OFF, FAIL	35	OPEN RELAY, RPC OUTPUT COMMAND
12	OTS	24	INCOMING CONTROL POWER ON, READY	36	
13	OPEN TORQUE RELAY (LATCH, N.O / N.C*)	25		37	
14	S1 : CLS*	26		38	
15	FULL CLOSE (LATCH, N.O* / N.C)	27		39	
				40	AI+ 4~20mA*0~5V/0~10V/1~5V/2~10V
				41	AI- 4~20mA*0~5V/0~10V/1~5V/2~10V
				42	AO+ 4~20mA
				43	AO- 4~20mA
				44	
				45	
				46	
				47	
				48	24V+
				49	24V-
				50	LIVE
				51	NEUTRAL
					INCOMING CONTROL POWER DC 24V
					INCOMING CONTROL POWER AC 87V-264V

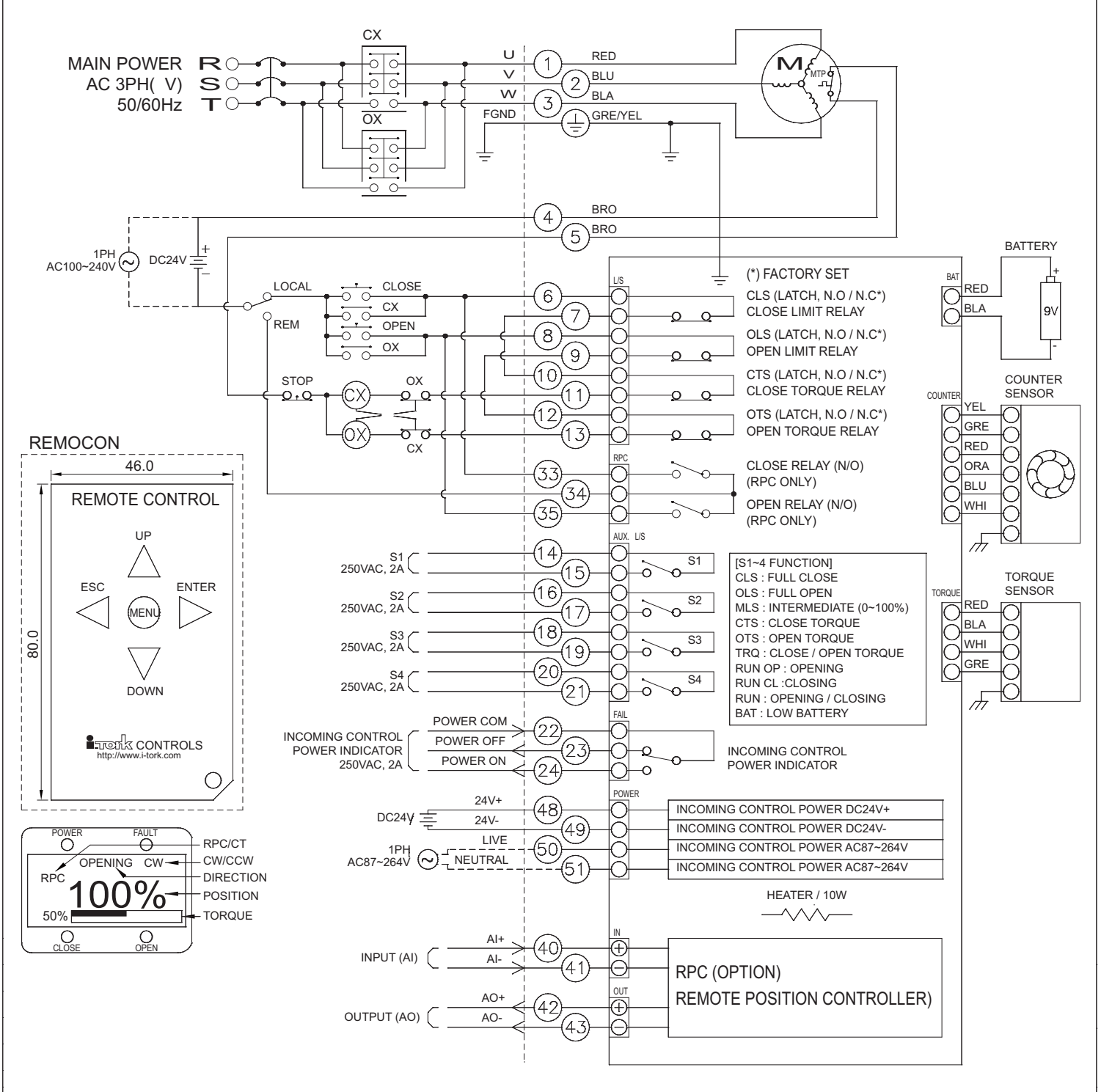

**OPTION NAME : INTEGRAL**

1	FGND						
2	3PH POWER "R"						
3	3PH POWER "S"						
4	INTERNAL CONTROL POWER DC 24V-	16	S6 : REV*	28	STOP (OPEN) / MAINTAIN (SHUT)	40	
5	INTERNAL CONTROL POWER DC 24V+	17	*REVERSE 3PH (LATCH, N.O* / N.C)	29	OPEN	41	
6	S1 : CLS*	18	S7 : RUN CL*	30	EXTERNAL CONTROL POWER AC/DC 24V-	42	
7	FULL CLOSE (LATCH, N.O* / N.C)	19	*CLOSING (LATCH, N.O* / N.C)	31	EXTERNAL CONTROL POWER AC 110V/220V	43	
8	S2 : OLS*	20	S8 : RUN OP*	32		44	
9	FULL OPEN (LATCH, N.O* / N.C)	21	*OPENING (LATCH, N.O* / N.C)	33	ESD	45	
10	S3 : CTS*	22	3PH POWER FAIL/READY, COM	34		46	
11	CLOSE TORQUE (LATCH, N.O* / N.C)	23	3PH POWER OFF, FAULT	35		47	
12	S4 : OTS*	24	3PH POWER ON, READY	36		48	
13	OPEN TORQUE (LATCH, N.O* / N.C)	25		37		49	
14	S5 : REMOTE*	26	MODULATION (RPC/PROFIBUS/CANopen/Etc.)	38		50	
15	*REMOTE MODE (LATCH, N.O* / N.C)	27	CLOSE	39		51	

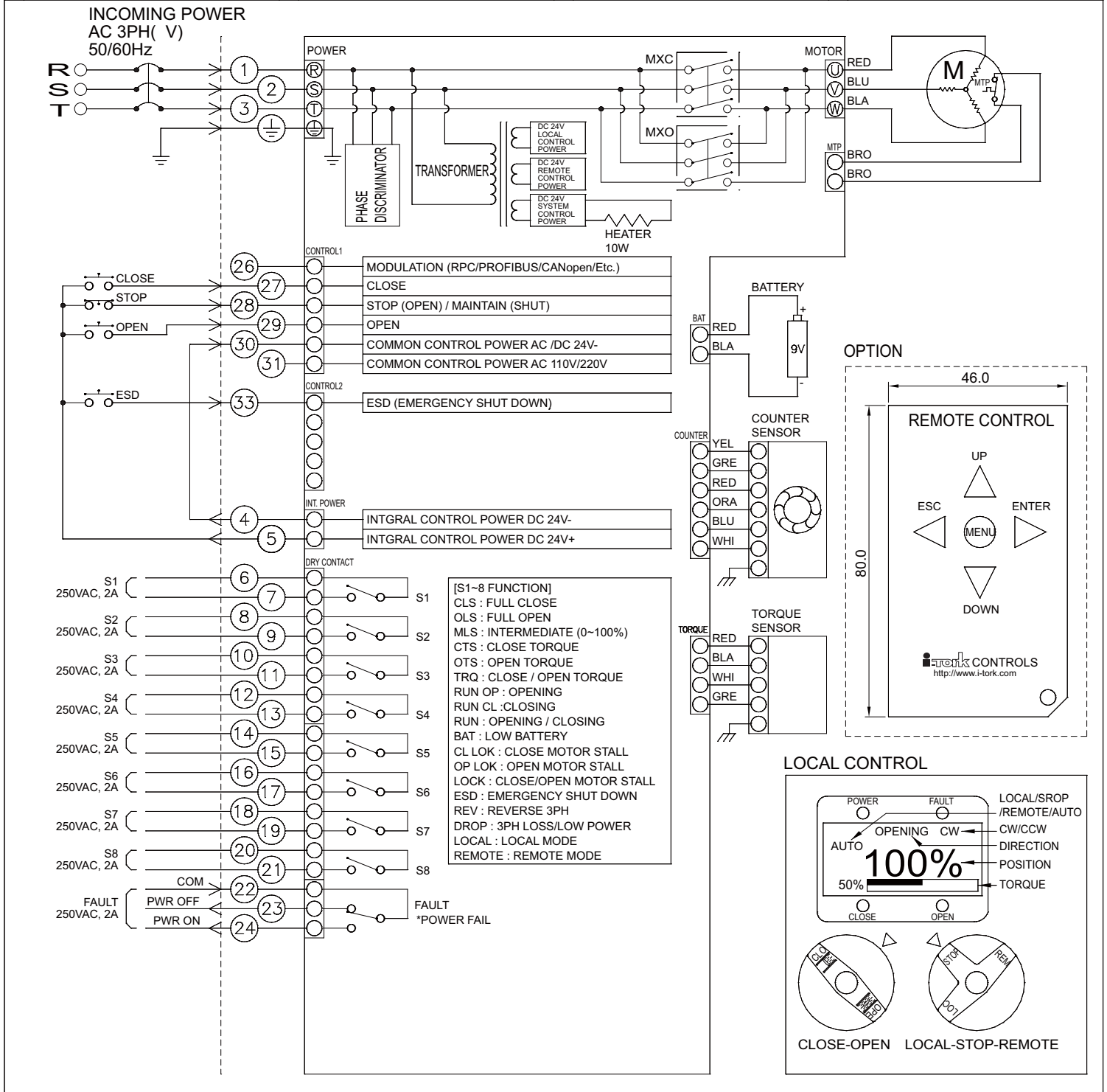

OPTION NAME : INTEGRAL + RPC

FGND			
1 3PH POWER "R"			
2 3PH POWER "S"			
3 3PH POWER "T"			
4 INTERNAL CONTROL POWER DC 24V-	16 S6 : REV*	28 STOP (OPEN) / MAINTAIN (SHUT)	40 AI+ 4~20mA*0~5V/0~10V/1~5V/2~10V
5 INTERNAL CONTROL POWER DC 24V+	17 *REVERSE 3PH (LATCH, N.O* / N.C)	29 OPEN	41 AI- 4~20mA*0~5V/0~10V/1~5V/2~10V
6 S1 : CLS*	18 S7 : RUN CL*	30 EXTERNAL CONTROL POWER AC/DC 24V-	42 AO+ 4~20mA
7 FULL CLOSE (LATCH, N.O* / N.C)	19 *CLOSING (LATCH, N.O* / N.C)	31 EXTERNAL CONTROL POWER AC 110V/220V	43 AO- 4~20mA
8 S2 : OLS*	20 S8 : RUN OP*	32	44
9 FULL OPEN (LATCH, N.O* / N.C)	21 *OPENING (LATCH, N.O* / N.C)	33 ESD	45
10 S3 : CTS*	22 3PH POWER FAIL/READY, COM	34	46
11 CLOSE TORQUE (LATCH, N.O* / N.C)	23 3PH POWER OFF, FAULT	35	47
12 S4 : OTS*	24 3PH POWER ON, READY	36	48
13 OPEN TORQUE (LATCH, N.O* / N.C)	25	37	49
14 S5 : REMOTE*	26 MODULATION (RPC/PROFIBUS/CANopen/Etc.)	38	50
15 *REMOTE MODE (LATCH, N.O* / N.C)	27 CLOSE	39	51

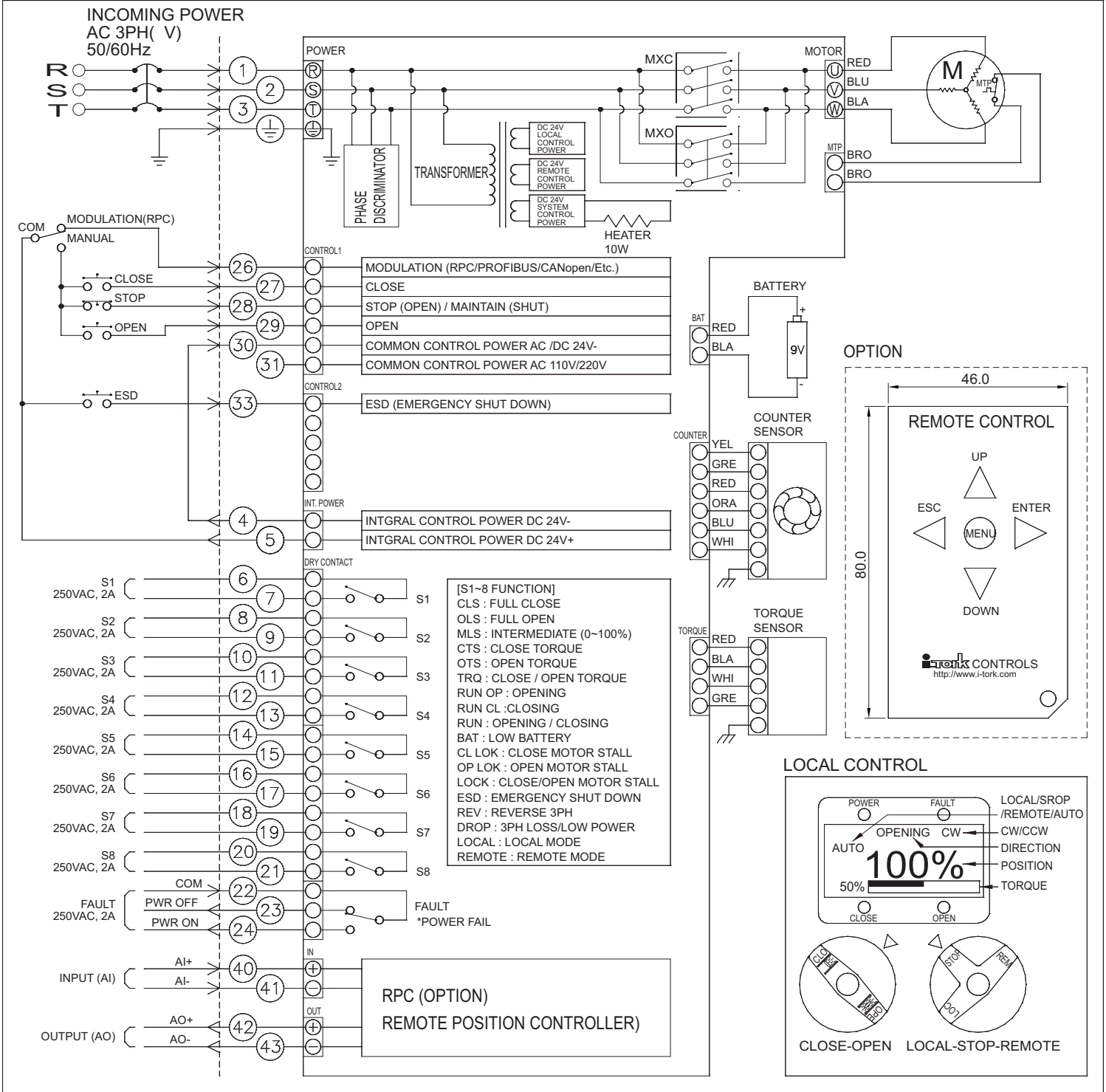

# MULTI-TURN ACTUATOR ITM SERIES



\* The details of this catalog are subject to change without prior notification.

---

Valve and Flow Control Specialists  
BRISBANE - SYDNEY - MELBOURNE - DARWIN  
Email: [sales@valveandflowcontrolspecialists.com](mailto:sales@valveandflowcontrolspecialists.com)