

Electric Actuator ITQ Series

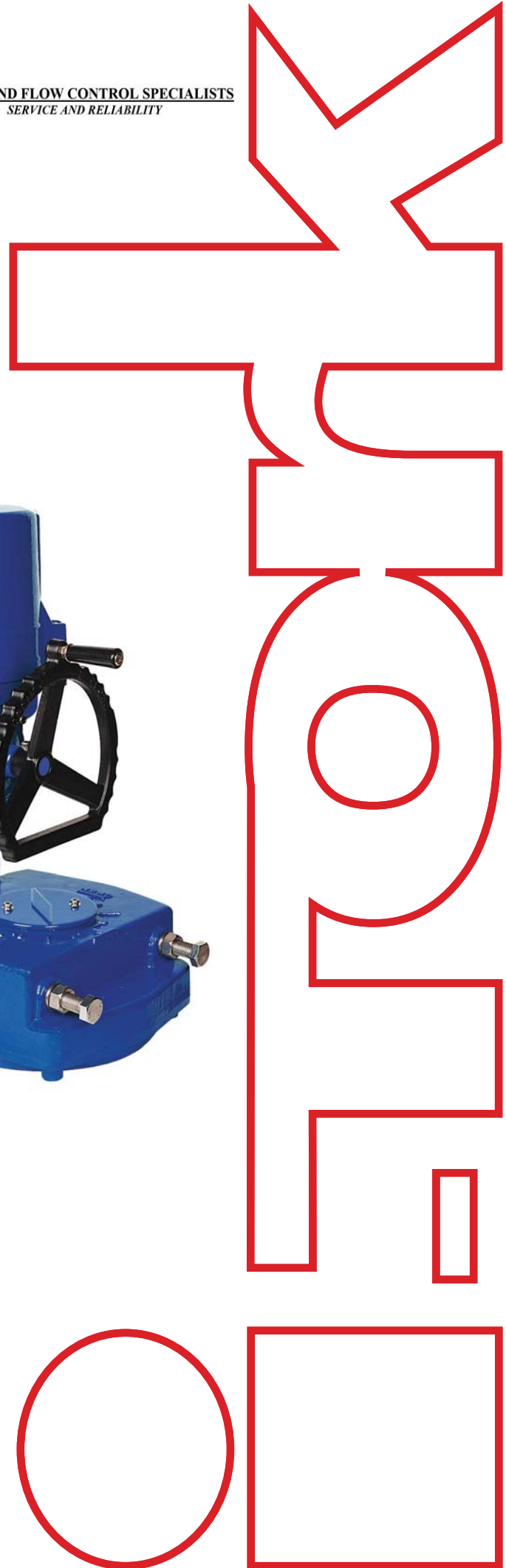

VALVE AND FLOW CONTROL SPECIALISTS
SERVICE AND RELIABILITY



Valve and Flow Control Specialists
BRISBANE - SYDNEY - MELBOURNE - DARWIN
Email: sales@valveandflowcontrolspecialists.com
www.valveandflowcontrolspecialists.com



KTL

ITQ ELECTRIC ACTUATOR

INTRODUCTION

- I-Tork controls designs, produces and provides high quality actuators and services related to valve automation.
- Our long years experience in the automation field enables us to launch our ITQ series electric actuator which has compact size, robust construction, reliable performance and ability to integrate fully into sophisticated control systems.
- I-Tork controls is always ready to provide you with our ITQ series actuator and accessories, with quality service.

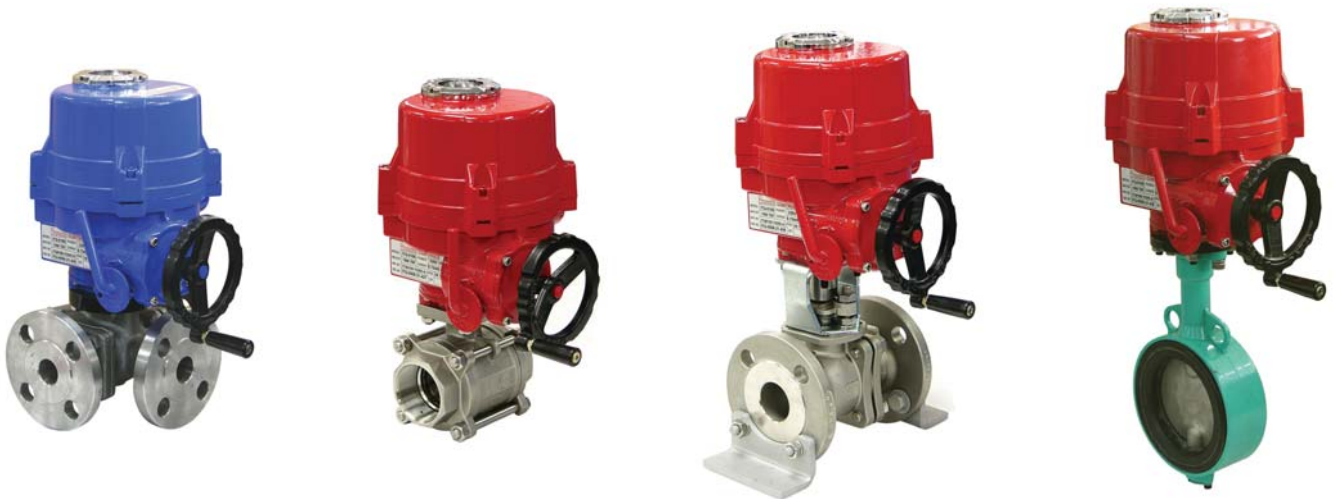
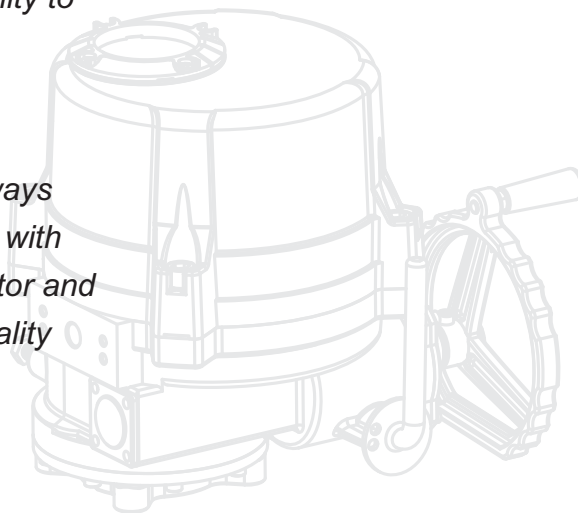
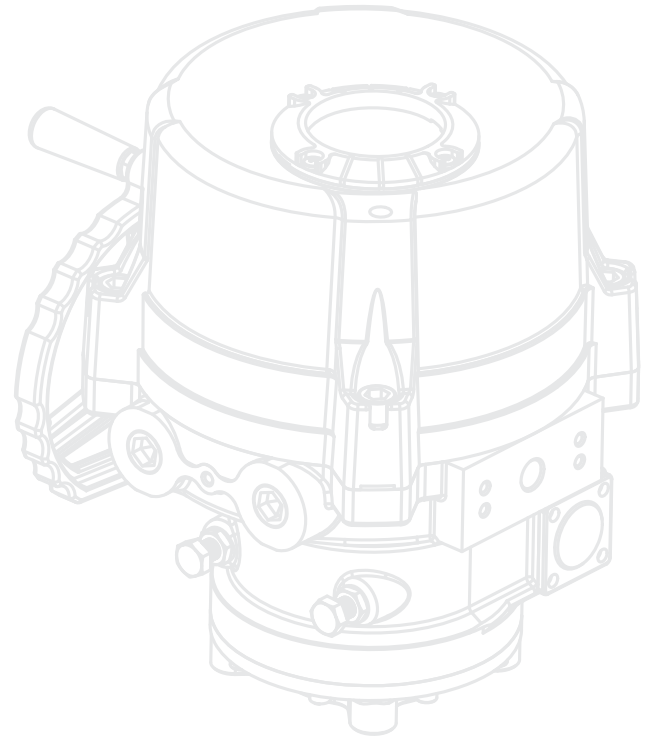

FEATURES

- Compact and robust construction, light weight providing high output torque (Max 9000Nm).
- Wide range of torque variation (From min 100Nm to max 9000Nm).
- Hard anodized aluminum housing inside and outside with external powder coated against severe industrial environment.
- Enclosure using radial seals & O-rings that provide protection to waterproof IP67 (Nema 4 & 6) and optional watertight IP68
- Mounting base according to ISO5211 standard.
- Removable drive bushing for easy machining and mounting.
- Self-locking provided by double worm gearing (no brake required).
- Auto-declutching manual override handwheel with padlockable auto / manual switchable lever.
- Reliable Mechanical Torque sensing system providing safe operation in overload condition.
- Large size window and indicator provides better position indication from a distance.
- Various Local position control options providing easy commissioning and operation in field.
- Digitalized control component.

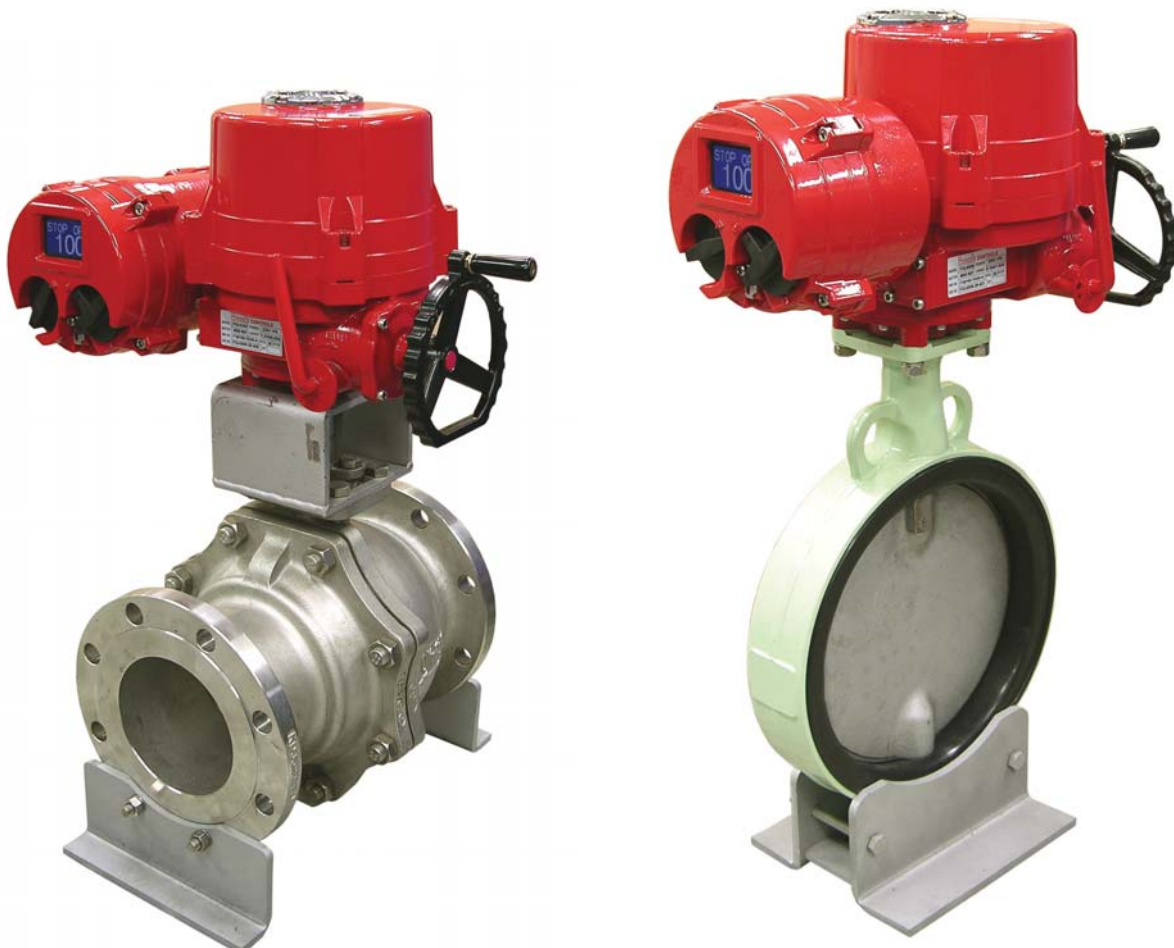

CONSTRUCTION



External mechanical stopper

- Prevents over run of travel angle when limit switch fails.

Cable entries

- Standard 2-PF3/4(Max 1) for various cable gland.

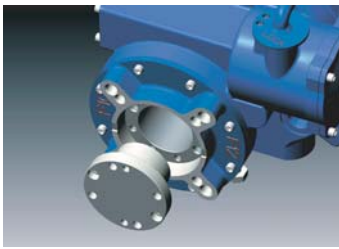

Removable drive bushing and ISO5211 mounting base

- (F07~F30) for easy mounting on valve.

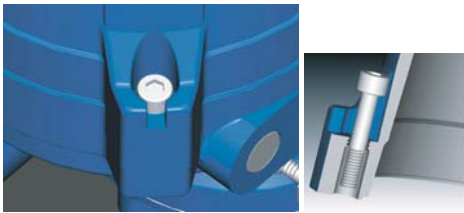

Captive cover bolts

- Designed to prevent losing it during maintenance or installation.
- * All external bolts are stainless steel for rust prevention.

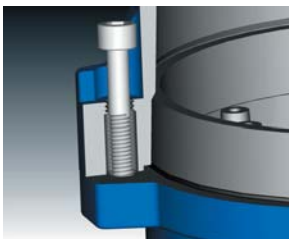

Standard

Tapered interface between cover and lower housing

- For easy lifting cover up from lower housing for wiring or maintenance.

① Housing

- Hard anodized Aluminum casting and external epoxy powder coated against severe industrial environment.

② Gearing

- Precisely machined double worm gear c/w minimum back-lash, low noise, high output torque.

③ Self locking

- Provided by double worm gearing to keep position of valve unchanged against reverse torque from valve.

④ Sealing

- By O-ring in all interfaces IP67(standard), and double o-ring for IP68 (option)

⑤ Handwheel

- Different sizes depending on actuator torque, and knob on handwheel for easy operation.

⑥ Motor

- Specially designed induction motor to generate high starting torque and high efficiency equipped with thermal protector to prevent damage from over heating.
- Insulation class F





Indicator

- Continuous mechanical position indicator and window with dial



Torque switches

- Protect actuator from damage caused by overload from the driven valve over the whole travel.
- 1 each for open / close



Limit switches

- Directly engaged with driving shaft to set accurate position of valve.
- 2 ea for each travel end (open/close).
- Optional Extra Limit Switches (Max 4 ea for each end) : Except for ITQ0100

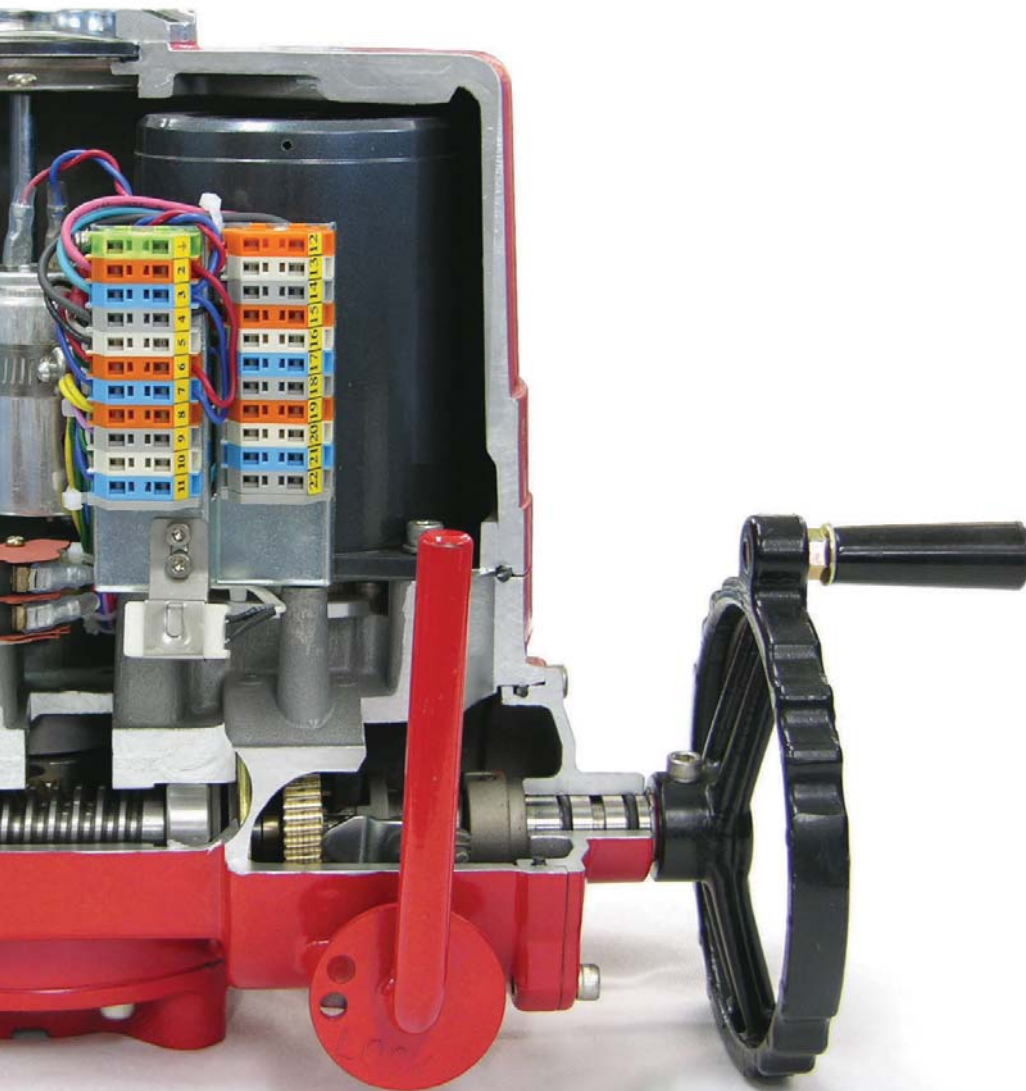

Terminal

- Spring loaded push type terminal for tight wiring connection under severe vibration.



Manual override

- Auto / Manual switchable lever and handwheel engagement for emergency manual operation.
- Drive force automatically resorted by motor start, unless lever padlocked to prevent this occurring.



Space Heater

- Anti-condensation

ITQ ELECTRIC ACTUATOR

TECHNICAL INFORMATION

Model	ITQ 0100	ITQ 0160	ITQ 0240	ITQ 0350	ITQ 0500	ITQ 0800	ITQ 1100	ITQ 2000	ITQ 3000	ITQ 6000	ITQ 9000
Rated torque (Nm)	100	160	240	350	500	800	1100	2000	3000	6000	9000
Duty cycle S4 (%)	50	50	50	50	30	25	25	25	25	25	25
Operating time (second)											
50Hz	21	26	26	31	31	39	39	59	59	178	178
60Hz	18	22	22	26	26	32	32	50	50	149	149
24DC(No Load)	18	33	33	37	34	-	-	-	-	-	-
Max bore Size (mm)											
Key (∅)	22	25	25	40	40	48	48	75	75	120	120
Square(∅)	20	23	23	34	34	40	40	64	64	100	100
Rated current (A)											
1Phase / 110V / 50Hz	0.98	1.60	1.62	1.72	3.60	3.90	3.90	4.95	6.6	4.95	6.6
60Hz	1.10	1.70	1.72	1.80	3.90	4.20	4.30	4.55	6.1	4.55	6.1
1Phase / 220V / 50Hz	0.52	0.85	0.87	0.92	1.50	2.05	2.15	2.95	3.75	2.95	3.75
60Hz	0.58	0.90	0.90	0.95	1.60	2.20	2.30	3.15	3.85	3.15	3.85
3Phase / 380V / 50Hz	0.43	0.30	0.32	0.32	0.52	0.82	0.84	1.5	1.6	1.5	1.6
60Hz	0.33	0.30	0.32	0.32	0.56	0.88	0.90	1.8	2.0	1.8	2.0
3Phase / 440V / 50Hz	0.59	0.30	0.32	0.32	0.55	0.82	0.84	2.3	2.5	2.3	2.5
60Hz	0.42	0.32	0.35	0.35	0.58	0.88	0.88	2.2	2.4	2.2	2.4
AC / DC 24V	2.8	1.8	2.4	3.8	5.0	-	-	-	-	-	-
Motor insulation class	F	F	F	F	F	F	F	F	F	F	F
ISO 5211 mounting flange	F07	F07/F10	F07/F10	F10/F12	F10/F12	F12/F14	F12/F14	F16	F16	F25/F30	F25/F30
Weight (Kgs)	7	15	15	20	20	25	25	42	42	152	152
No of handwheel turns	10	12	12	14	14	17	17	13	13	39	39

STANDARD SPECIFICATION



Enclosure	Weatherproof IP67, NEMA4 4X and 6, O-ring sealed
Main Power supply	110/220VAC/1Ph/50/60Hz, 380/440/VAC/3Ph/50/60/Hz ±10%, 24VDC
Control power supply	110/220VAC/1Ph/50/60Hz ±10%
Duty cycle(on-off)	S2: 10Min~30Min
Duty cycle(modulating)	S4, 30~50%, 300~1200 start/Hour
Motor	Squirrel Cage induction motor
Limit switches	2 each for Open and Close (SPDT 250VAC/10A rating)
Torque switches	1 each for Open and Close (SPDT 250VAC/10A rating except for ITQ 0100)
Stall protection/ set temp.	Built in Thermal protection, Open 150°C±5°C, Close 97°C±15°C
Travel angle	90° ± 5° (0° ~ 100°)
Position indicator	Continuous mechanical indicator with arrow
Manual override	De-clutchable
Self locking	Provided by double worm gearing (no brake)
Mechanical stopper	1 each for each travel end (Open and Close), external & adjustable
Space Heater	5W(110/220VAC) for anti-condensation
Cable entries	2 - PF 3/4 TAP
Lubrication	EP type grease
Terminal block	Screw and Lever Push type (spring loaded)
Ambient temperature	Basic actuator : -20°C~+70°C c/w control options : -10°C~+60°C
Ambient humidity	90%RH Max (Non-Condensing)
Anti vibration	XYZ 10g. 02~34Hz, 30 minutes
External coating	Dry powder (Polyester)

OPTIONS AVAILABLE

Mechanical

Symbol	Description	Remark
EX	Explosion proof (Ex d II B T4)	Approved by KTL, ATEX, NEPSI
WT	Watertight (IP68), Temporary submersible	10M Head 100hours
ALS	Auxiliary limit switches (Max 2 for each travel end)	
ATS	Auxiliary torque switches (Max 2 for each travel end)	Except for ITQ 0100
EXT	Extended travel angle (up to 120°, 135°, 180°, 270°)	Except for ITQ with Gear box
SV	Variation in torque and operating speed	Please consult before ordering

Remote monitoring and control

PK	Potentiometer kit (output signal : 0~1 Kohm) High resolution potentiometer and precisely machined gearing are directly engaged with drive shaft to feedback continuous position of valve		PK
CT	Current transmitter (output signal : 4-20mA) Zero / Span Adjustment		CT
RPC / Signal configuration	Remote position controller (by input and output signal) Input : 4-20mA, 0-10VDC, 2~10VDC, 1~5VDC, 0~5VDC Output : 4-20mA (Option : 0-10VDC, 2~10VDC, 1~5VDC, 0~5VDC) Auto-calibration Reverse operating direction		RPC
Bus Communication	Profibus Communication CANopen Communication		

Local control



LP4 / LM4

LP4 for 1 & 3 Phase (ITQ 0100~9000)

Control power : Free Voltage (85~265VAC) 50/60Hz, Option : 24VDC
Magnetic selector switches, SMPS (Switching Module Power Supply)
: Open/Close & Local/Stop/Remote

Local lamp indication

- : Power - White(on), Remote : Blue(on),
- : In case of Close Torque Switch Trip -
Yellow(on) + Green (flickering : only at Local Position)
- : In case of Open Torque Switch Trip -
Yellow(on) + Red (flickering : only at Local Position)
- : Full Close - Green(on), Closing - Green(flickering : only at Local Position)
- : Full Open - Red(on), Opening - Red(flickering : only at Local Position)

* Options Available : PK, CT, RPC(Modulating), IP68, Explosion proof

LM4 for 3 Phase (ITQ 0100~9000)

Including the same functions as LP4
Reversing electric contactors, Transformer

Local control



ICM1

ICM1 for 1 & 3 Phase (Integral Control Module) (ITQ 0160~9000)

Main Power : 3Ph / 220/380/440 VAC
1Ph / 110/220 VAC

Control power : 24 VDC (Internal Power)
(Option : 110 VAC, 220 VAC (External Power))

Magnetic selector switches

: Open/Close & Local/Stop/Remote

Reversing electric contactors, Transformer, Phase Detector

Auto-Phase Discriminator

Local lamp indication

: Power - White(on), Remote : Blue(on),

: In case of Close Torque Switch Trip - Yellow(on) + Green(flickering)

: In case of Open Torque Switch Trip - Yellow(on) + Red(flickering)

: Full Close - Green(on), Closing - Green (flickering)

: Full Open - Red(on), Opening - Red (flickering)

Single & Reverse Phasing : (Yellow + Green + Red) all flickering

* Options Available : Explosion Proof, IP68

ICM2 for 1 & 3 phase (integral with LCD Display) (ITQ 0160~9000)

Including the same functions as ICM1

Reversing electric contactors, Transformer,

Auto-Phase Discriminator, LCD Display

* Options Available : CT, RPC(Modulating),
Explosion Proof,
IP68, Bus Communication



ICM2

ICM3 for 1 & 3 phase (integral with LCD Display/IP68 Enclosure) (ITQ 0160~9000)

Including the same functions as ICM2

Reversing electric contactors, Transformer, Auto-Phase Discriminator,

LCD Display, IP68, Explosion Proof, RPC(Modulating), Bus Communication,

34pins separate compartment for terminal block

Fail safe

BP for 1 Phase (ITQ 0160~0500)

Motor : 24 VDC

Rechargeable Battery back up - Fail safe function

When Main power is alive, actuator works as normally.

Once power fails, actuator will move to pre-set fail safe position.

Input power : Free Voltage (85~265 VAC) 50/60Hz

Output contacts : open/close/Alarm relay

LED signal indication : 4 LEDs (Full Open/Close, Over Torque and Power)

Rechargeable battery : 2.0AH 27.5VDC(Ni-Cd)



BASIC ACTUATOR DIMENSIONS

With Gear Box

Type	ITQ 0100	ITQ 0160	ITQ 0240	ITQ 0350	ITQ 0500	ITQ 0800	ITQ 1100	ITQ 2000	ITQ 3000	ITQ 6000	ITQ 9000
Flange	F07	F07	F07	F10	F10	F12	F12	F16	F16	F25	F25
ISO5211		F10	F10	F12	F12	F14	F14			F30	F30
C	∅ 70	∅ 70 ∅ 102	∅ 70 ∅ 102	∅ 102 ∅ 125	∅ 102 ∅ 125	∅ 125 ∅ 140	∅ 125 ∅ 140	∅ 165	∅ 165	∅ 254 ∅ 298	∅ 254 ∅ 298
A	M8	M8/M10	M8/M10	M10/M12	M10/M12	M12/M16	M12/M16	M20	M20	M16/M20	M16/M20
B	14	14/17	14/17	17/21	17/21	20/25	20/25	32	32	30/35	30/35
D(Key)	∅ 22	∅ 25	∅ 25	∅ 40	∅ 40	∅ 48	∅ 48	∅ 75	∅ 75	∅ 120	∅ 120
D(Squ.)	□ 20	□ 23	□ 23	□ 38	□ 38	□ 40	□ 40	□ 64	□ 64	□ 100	□ 100
E	∅ 50	∅ 58.5	∅ 58.5	∅ 80	∅ 80	∅ 95	∅ 95	∅ 135	∅ 135	∅ 216	∅ 216
F	∅ 88	∅ 125	∅ 125	∅ 148	∅ 148	∅ 178	∅ 178	∅ 226	∅ 226	∅ 350	∅ 350
G	3	3	3	3	3	3	3	5	5	5	5
H	37	57	57	62	62	67	67	90	90	114	114
S	125	140	140	170	170	195	195	225	225	225	225
X	258	338	338	357	357	380	380	440	440	532	532
Y	172	229	229	244	244	287	287	375	375	417	417
Z	245	284	284	313	313	338	338	385	385	668	668

(mm)

(mm)

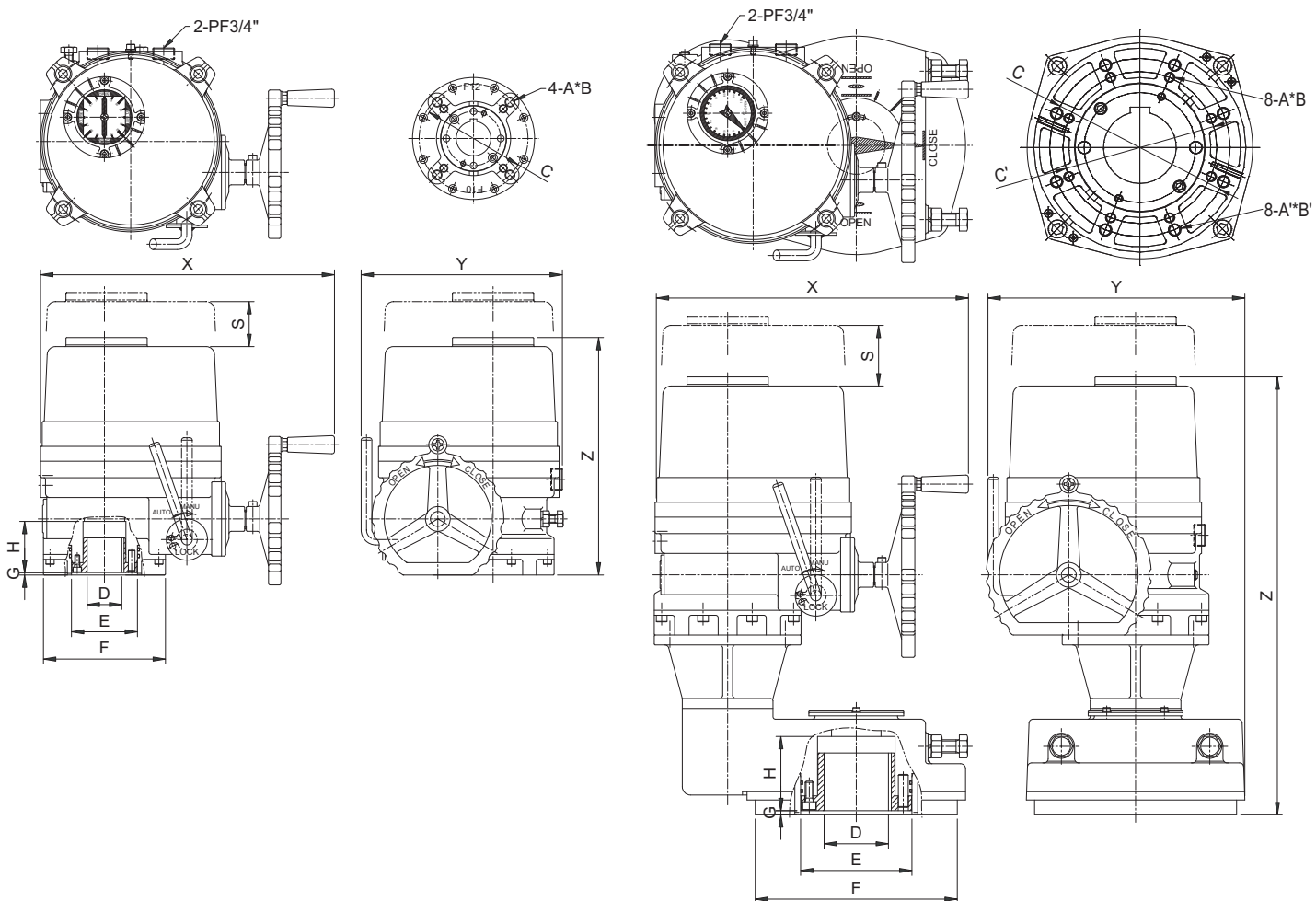

ITQ ELECTRIC ACTUATOR

CONTROL OPTION DIMENSIONS

(mm)

Type	RPC			CT			BP			LP4 / LM4 / ICM1 / ICM2			ICM3		
	X	Y	Z	X	Y	Z	X	Y	Z	X	Y	Z	X	Y	Z
ITQ 0100	340	190	220	316	172	220	428	172	220	X			X		
ITQ 0160 / 0240		O			O		508	229	259	499	229	259	517	284	259
ITQ 0350 / 0500		O			O		527	244	288	518	244	288	536	284	288
ITQ 0800 / 1100		O			O		X			541	284	313	559	284	313
ITQ 2000 / 3000		O			O		X			600	375	385	620	375	385
ITQ 6000 / 9000		O			O		X			677	417	668	697	417	668

* O : Installed inside of actuator

* X : Not available

* Z : Height of basic actuator

ITQ 0100

ITQ 0160 ~ 9000

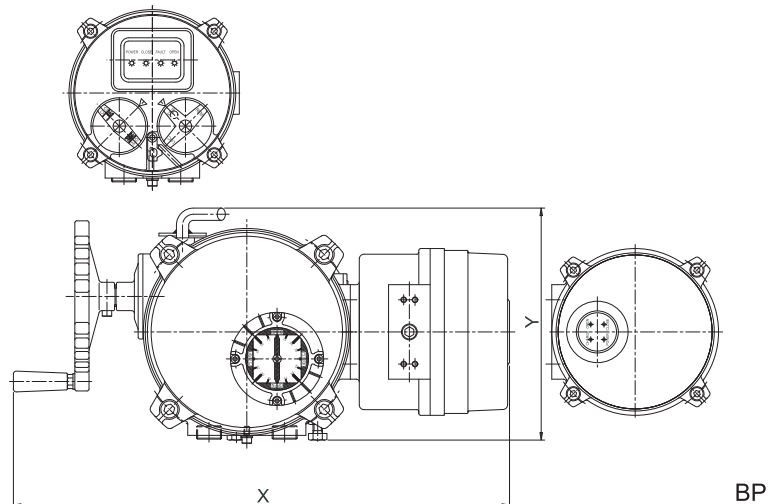
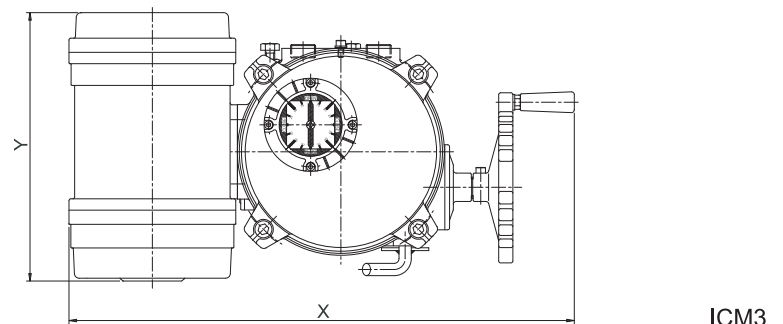
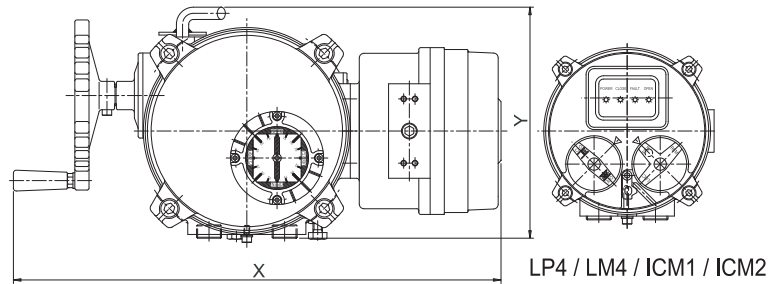
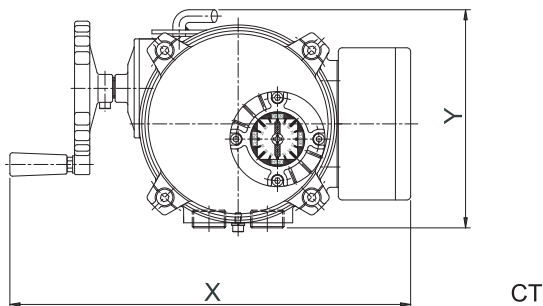
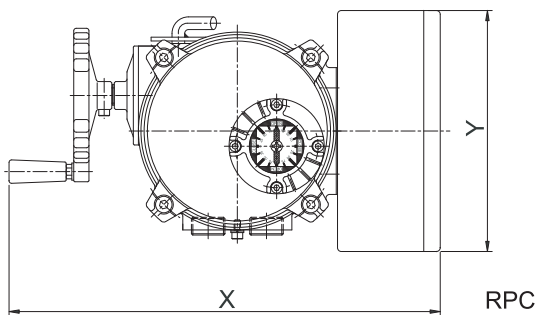

TYPICAL WIRING (ITQ 0100)

110/220VAC/50/60Hz, 1Ph(On-Off)

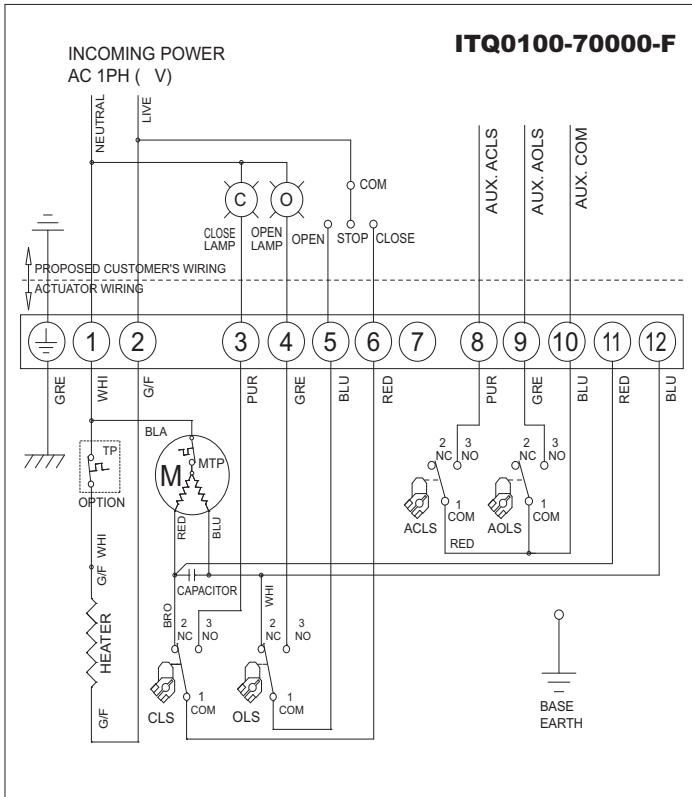

110/220VAC/50/60Hz, 1Ph(Modulating : RPC)

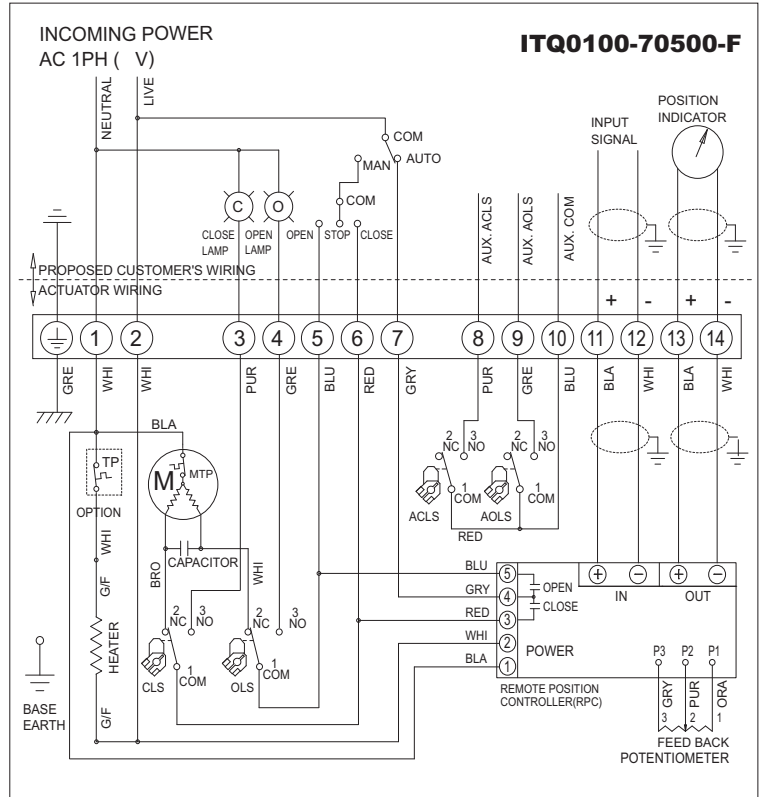

380/440VAC/50/60Hz, 3Ph(On-Off)

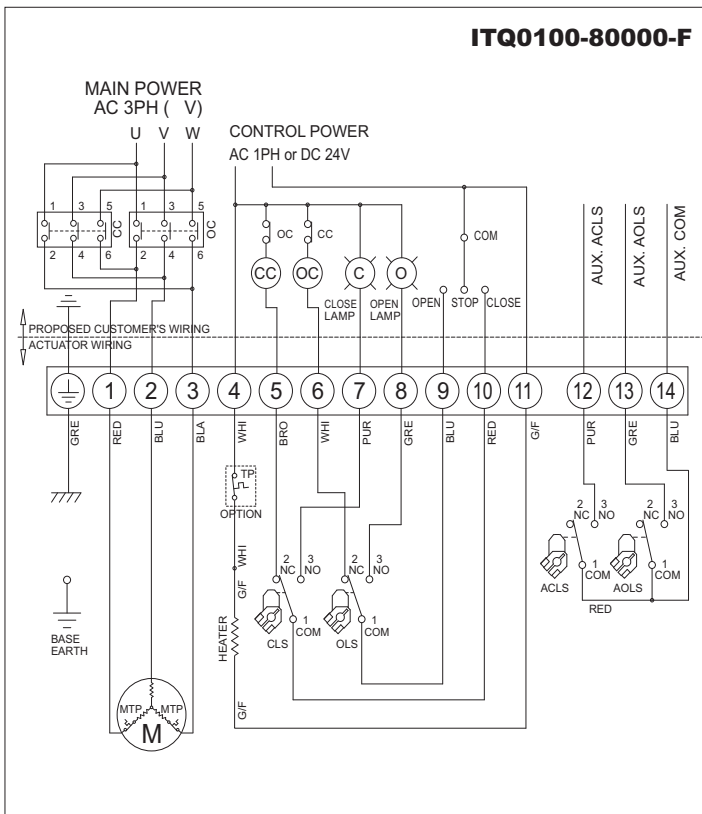

TORQUE AND LIMIT SWITCHES OPERATION

SWITCH	CLOSE ←	INTERMEDIATE	→ OPEN
CLS 1-2	█		
CLS 1-3	█		
OLS 1-2		█	
OLS 1-3		█	
ACLS1-2		█	
ACLS1-3	█		
AOLS1-2		█	
AOLS1-3			█
CTS 1-3	Closing Torque Switch interrupts control if Mechanical overload occurs during closing cycle		
OTS 1-3	Opening Torque Switch interrupts control if Mechanical overload occurs during opening cycle		

Important Notice

1. The Electric Wiring Diagrams shall be modified with terminal no and wires in Red Color for our customers' convenience from 1st of June 2009.
2. Please only refer to the Wiring Diagram Sticker or separate Wiring Diagram inside of each actuator. If there is any confusion please contact our distributor.

TYPICAL WIRING (ITQ 0160 ~ ITQ 9000)

110/220VAC/50/60Hz, 1Ph(On-Off)

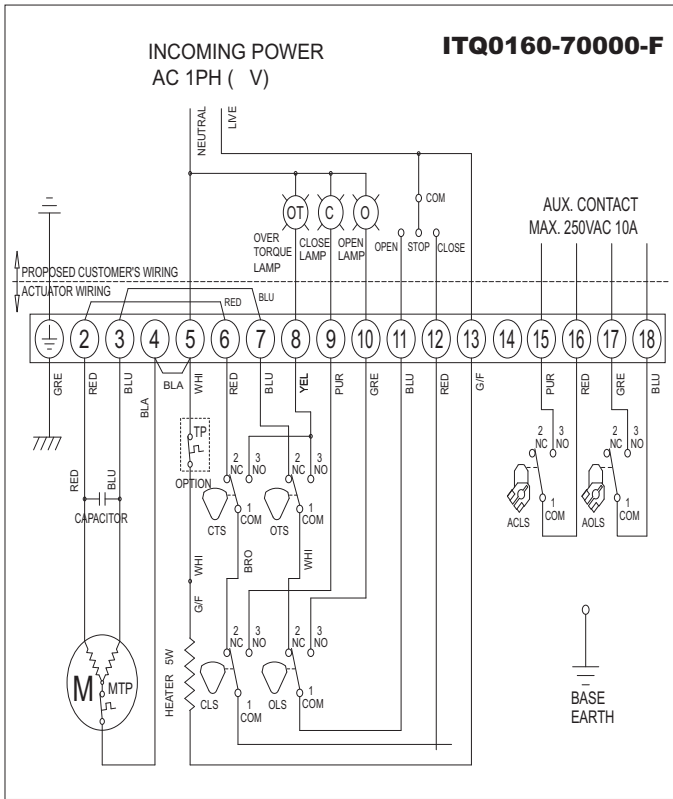

110/220VAC/50/60Hz, 1Ph(Modulating : RPC)

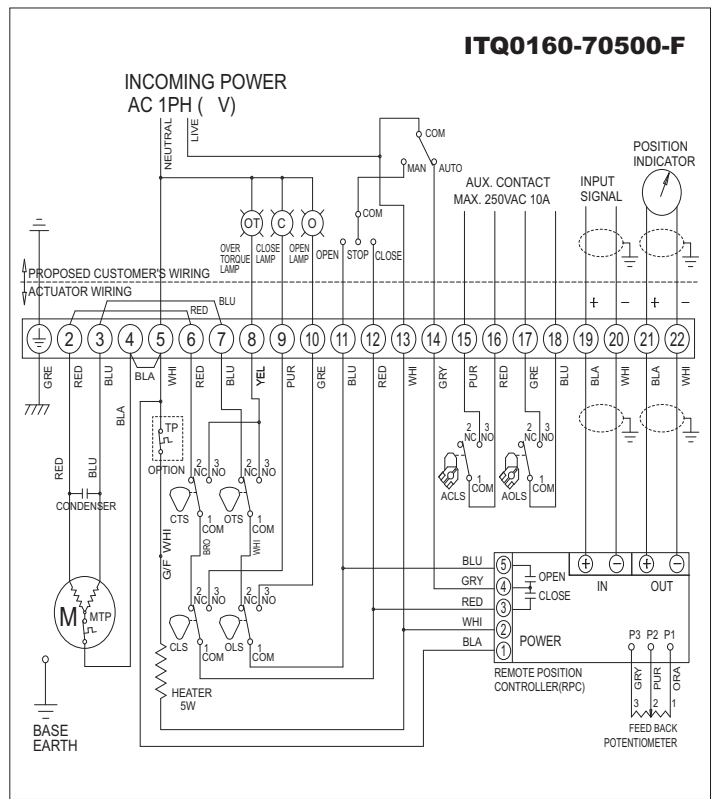

- ALS : Auxiliary Limit Switch
- AOLS : Auxiliary Open Limit Switch (Dry contact)
- ACLS : Auxiliary Close Limit Switch (Dry contact)
- O : Open Lamp
- C : Close Lamp
- OT : Over Torque Lamp
- CLS : Close Limit Switch (250VAC 10A)
- OLS : Open Limit Switch (250VAC 10A)
- CTS : Close Torque Switch (250VAC 10A)
- OTS : Open Torque Switch (250VAC 10A)
- CC : Close Magnetic Coil
- OC : Open Magnetic Coil
- M : Motor
- TP : Thermal Protector (250VAC 15A option)
- MTP : Thermal Protector built in motor

380/440VAC/50/60Hz, 3Ph(On-Off)

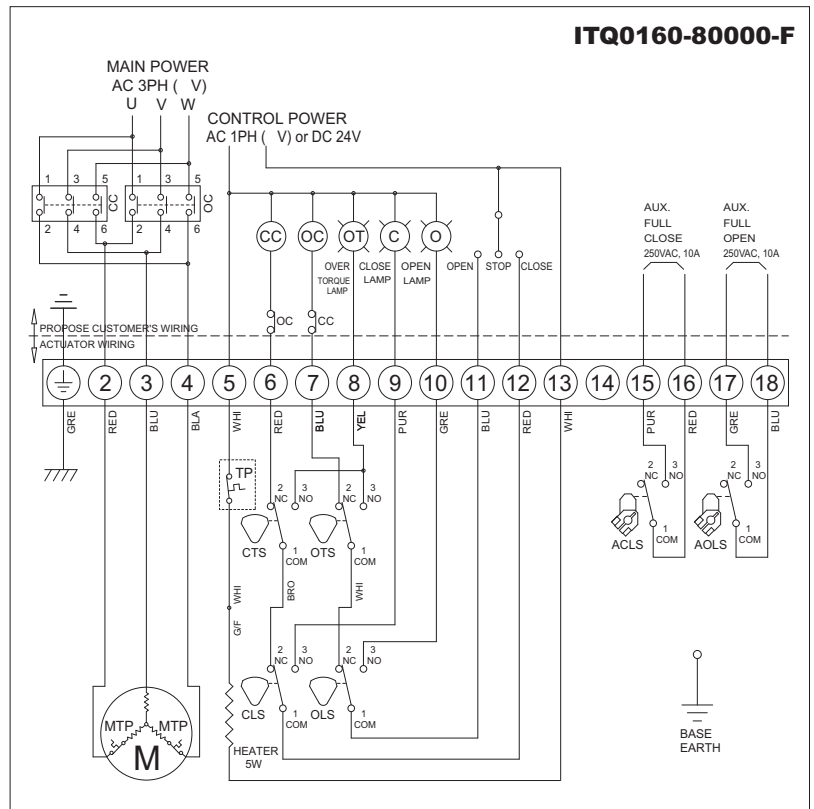

- * Each actuator should be powered through its own individual switch or relay contacts to prevent cross feed between two or more actuators.
- * In case of 3ph actuator, make sure to place actuator on the middle of travel angle before electrical operation to avoid "Jamming"
- * All internal wiring is done as color coding.

TYPICAL WIRING (ICM2 for 3phase)

ICMQ0160-82500-F

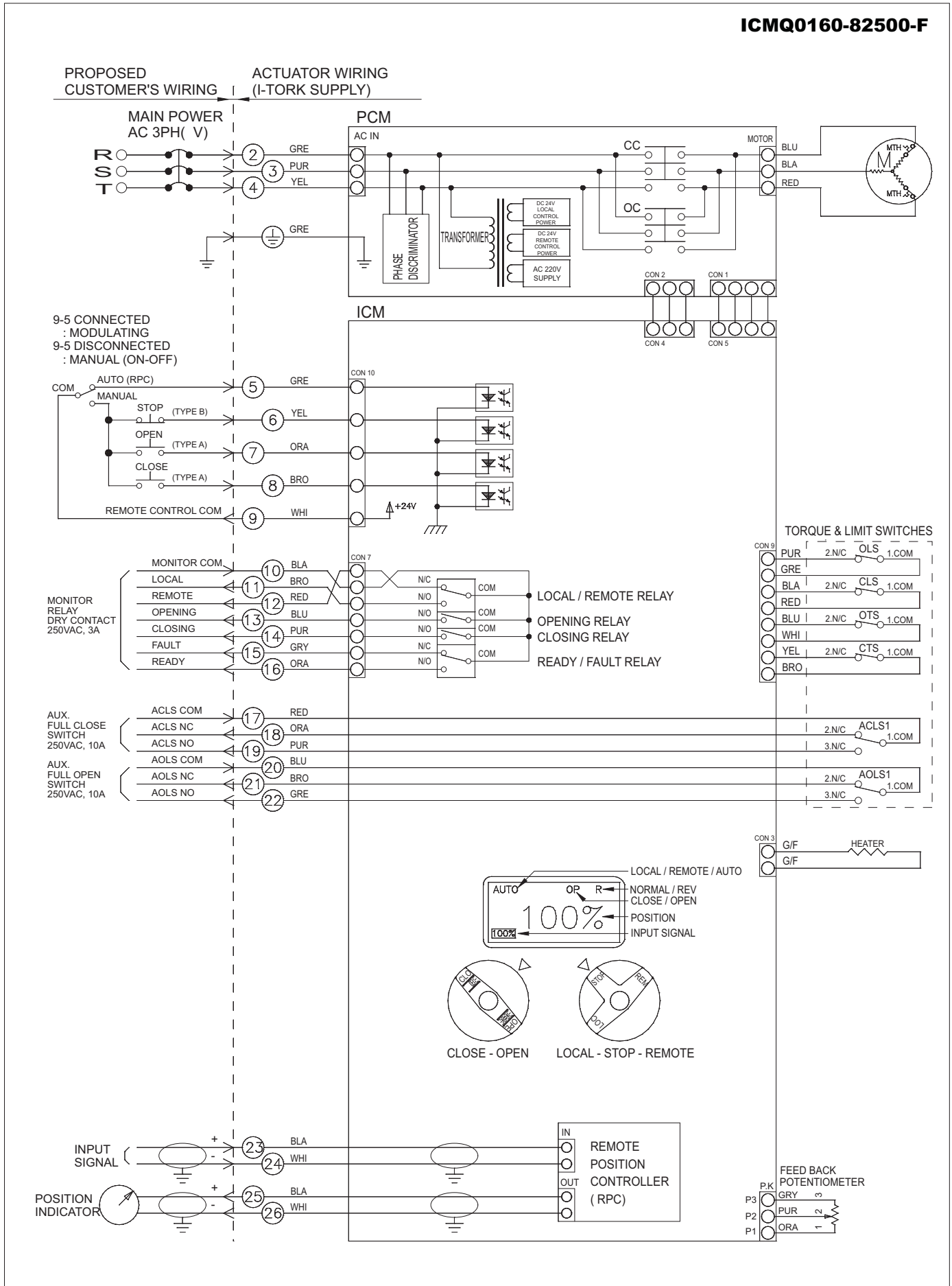

ITQ ELECTRIC ACTUATOR

ITQ Electric Actuator Standard selection guide for valves

Valve Actuator	Butterfly valve 10K ANSI 150#	2-Way Ball valve 10K ANSI 150#	3-Way Ball valve 10K ANSI 150#
ITQ 0100	100A (4")	40A (1 1/2")	40A (1 1/2")
ITQ 0160	125A (5")	50/65A (2",2 1/2")	50/65A (2",2 1/2")
ITQ 0240	150A (6")	80A (3")	80A (3")
ITQ 0350	200A (8")	100A (4")	
ITQ 0500	250A (10")	125A (5")	100A (4")
ITQ 0800	300A (12")	150A (6")	125A (5")
ITQ 1100	350A (14")		
ITQ 2000	450A (18")	250A (10")	200A (8")
ITQ 3000	500A (20")	300A (12")	250A (10")
ITQ 6000	600/750A (24",30")	350/400A (14",16")	300A (12")
ITQ 9000	800/900A (32",36")	450/500A (18",20")	350A (14")

* The above table is just reference without I-TORK's responsibility.

* Actuator sizing must be done based on actual valve torque.

The details of this catalog are subject to change without prior notification.

Valve and Flow Control Specialists
 BRISBANE - SYDNEY - MELBOURNE - DARWIN
 Email: sales@valveandflowcontrolspecialists.com
www.valveandflowcontrolspecialists.com