



GATE VALVES CLASS 150/300 BB, FF

DESIGN CODE: ASME B16.34, API600

FACE TO FACE : ASME B16.10

END FLANGE : ASME B16.5

WORKING PRESSURE : ASME B16.24

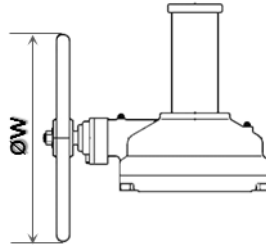
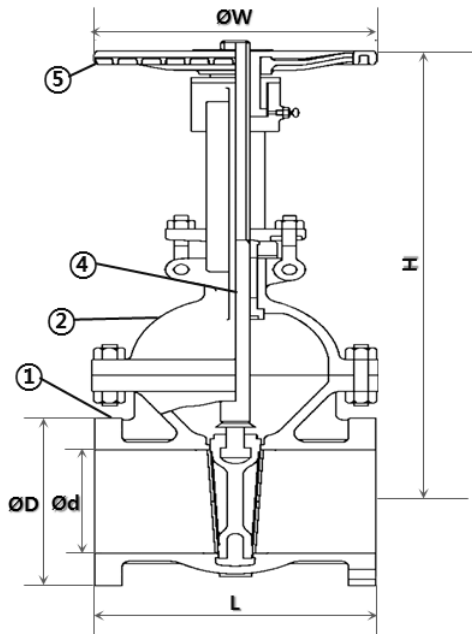

STANDARD MATERIAL SPECIFICATION

NO	NAME OF PART	METERIAL	
1	BODY	Bronze ASTM B61/B62	Ni-AL Bronze ASTM B148
2	BONNET	Bronze ASTM B61/B62	Ni-AL Bronze ASTM B148
3	DISC	Bronze ASTM B61/B62	Ni-AL Bronze ASTM B148
4	STEM	Bronze ASTM B584	Ni-AL Bronze ASTM B150
5	HANDWHEEL	Cast Iron ASTM A536	

*BOLTING METERIAL : A193 B8/ A194 8 STANDARD. UNLESS OTHERWISE SPECIFIED PURCHASE ORDER.

CLASS 150

SIZE	Ød	L	ØD	Øw	H
1/2"	13	108	90	90	170
3/4"	20	117	100	100	190
1"	26	127	110	100	230
1. 1/4"	32	140	115	125	270
1. 1/2"	39	165	125	125	290
2"	51	178	150	200	298
2-1/2"	64	190	180	200	313
3"	77	203	190	224	360
4"	102	229	230	250	436
5"	127	254	255	315	495
6"	153	267	280	315	553
8"	204	292	345	355	702
10"	254	330	405	400	850
12"	305	356	485	450	1035
14"	337	381	535	500	1363
16"	388	406	595	500	1438
18"	439	432	635	630	1640
20"	489	457	700	710	1864
24"	591	508	815	710	2110

CLASS 300

DIMENSION (UNIT:MM)

SIZE	Ød	L	ØD	Øw	H
1/2"	13	140	95	90	180
3/4"	20	152	115	100	200
1"	26	165	125	100	250
1. 1/4"	32	178	135	125	290
1. 1/2"	39	190	155	125	310
2"	51	216	165	200	361
2-1/2"	64	241	190	200	386
3"	77	282	210	224	407
4"	102	305	255	250	499
5"	127	381	280	315	615
6"	153	403	320	355	661
8"	204	419	380	450	817
10"	254	457	445	450	985
12"	305	502	520	500	1138
14"	337	762	585	710	1300
16"	388	838	650	800	1745
18"	432	914	710	900	2010
20"	483	991	775	900	2330
24"	585	1143	915	1000	2784